

A. 主体関係 / Machine body / Maschinengehäuse / Corps de la machine / Cuerpo de la máquina

REF.NO.	CODE	Q'TY	ヒンメイ	NAME OF PARTS	RM
2	S20204001	1	ウワカバー	TOP COVER	
3	S02606000	1	ユリヨウケイマド	OIL GAUGE WINDOW	
4	062401212	4	ナベコ4X12	SCREW, PAN M4X12	
5	S20306000	1	ハツキン	PACKING	
7	S23337009	1	ゴムセン18.5	RUBBER CAP, 18.5	
8	S39607001	1	ソクメンカバー	FRAME SIDE COVER	
9	062400812	4	ナベコ4X8	SCREW, PAN M4X8	
10	S20345009	1	ゴムセン14	RUBBER CAP, 14	
11	S20309101	1	メンイタカバー	FACE PLATE COVER	
12	060400612	2	バインドM4X6	SCREW, BIND M4X6	
13	S20310001	1	オクリキコウカバー-B	COVER FOR FEED MECHANISM, B	
14	S20311000	1	ハツキン	PACKING	
15	060400812	6	バインドM4X8	SCREW, BIND M4X8	
16	S23367001	1	ファンカバー	FAN COVER	
17	060400812	2	バインドM4X8	SCREW, BIND M4X8	
18	061400812	1	サラコM4X8	SCREW, FLAT M4X8	
19	S20878000	1	ゴムセン5.3	RUBBER CAP, 5.3	
20	S20313000	1	オクリダイカバー	FEED BAR COVER	
21	S20314000	1	ハツキン	PACKING	
22	062401012	6	ナベコM4X10	SCREW, PAN M4X10	
23	S39564021	1	ウチカバー	INSIDE COVER	
24	S44536000	1	ウチカバーハツキン	PACKING, INSIDE COVER	
25-1	060401012	3	バインドM4X10	SCREW, BIND M4X10	
25-2	S23616101	1	シメネジ4X10	SCREW, M4X10	
25-3	S44535001	1	バインドM4X8シール	SCREW, BIND M4X8 SEAL	
26	061400812	1	サラコM4X8	SCREW, FLAT M4X8	
27	S39611001	1	マエカバー-Lクミ	FRONT COVER ASSY, L	
27-1	S39612001	1	マエカバー-L	FRONT COVER, L	
27-2	S39613001	1	マエカバーヒンジジク	FRONT COVER HINGE SHAFT	
27-3	S20319001	1	マエカバーヒンジ	FRONT COVER HINGE	
27-4	012400432	2	アナヒラ4X4	SET SCREW, SOCKET (FT) M4X4	
27-5	S20320101	1	マエカバーストツバ	FRONT COVER STOPPER	
27-6	S20321001	1	マエカバーバネ	FRONT COVER SPRING	
27-7	060400612	1	バインドM4X6	SCREW, BIND M4X6	
27-8	S20327101	1	マエカバートメイタ	STOPPER PLATE, FRONT COVER	
27-9	060400612	1	バインドM4X6	SCREW, BIND M4X6	
28	060401412	3	バインドM4X14	SCREW, BIND M4X14	
29	S38305001	1	マエカバー-S	FRONT COVER, S	
30	062400612	2	ナベコM4X6	SCREW, PAN M4X6	
31	012400832	1	アナヒラ4X8	SET SCREW, SOCKET (FT) M4X8	
32	012400432	1	アナヒラ4X4	SET SCREW, SOCKET (FT) M4X4	
33	S20324101	1	マエカバー-Lアンナイ	FRONT COVER GUIDE, L	
34	060400612	2	バインドM4X6	SCREW, BIND M4X6	
35	S20325001	1	マエカバートメイタバネ	PLATE SPRING	
36	060400612	1	バインドM4X6	SCREW, BIND M4X6	
37	S20328001	1	クロスプレート	CLOTH PLATE	
39	S20330100	1	クロスプレートササエカラー	CLOTH PLATE SUPPORT COLLAR	
40	S20331001	1	セットカラークミ	SET SCREW COLLAR ASSY	
40-1	012400432	1	アナヒラ4X4	SET SCREW, SOCKET (FT) M4X4	
42	012400632	1	アナヒラ4X6	SET SCREW, SOCKET (FT) M4X6	
43	S20334000	1	クロスプレートシタ	CLOTH PLATE (LOWER)	
44	118770001	3	ハツキン	PACKING	
45	025040132	4	ヒラザガネシヨウ4	WASHER, PLAIN S 4	
46	060400612	1	バインドM4X6	SCREW, BIND M4X6	
47	060401012	3	バインドM4X10	SCREW, BIND M4X10	
48	S20412000	2	ゴムセン3.7	RUBBER CAP, 3.7	
49	S39625151	1	クロスプレートトメイタバネ	SPRING, PLATE	
50	060400612	2	バインドM4X6	SCREW, BIND M4X6	
51	156482000	1	セン4	CAP, 4	

From the library of: Diamond Needle Corp

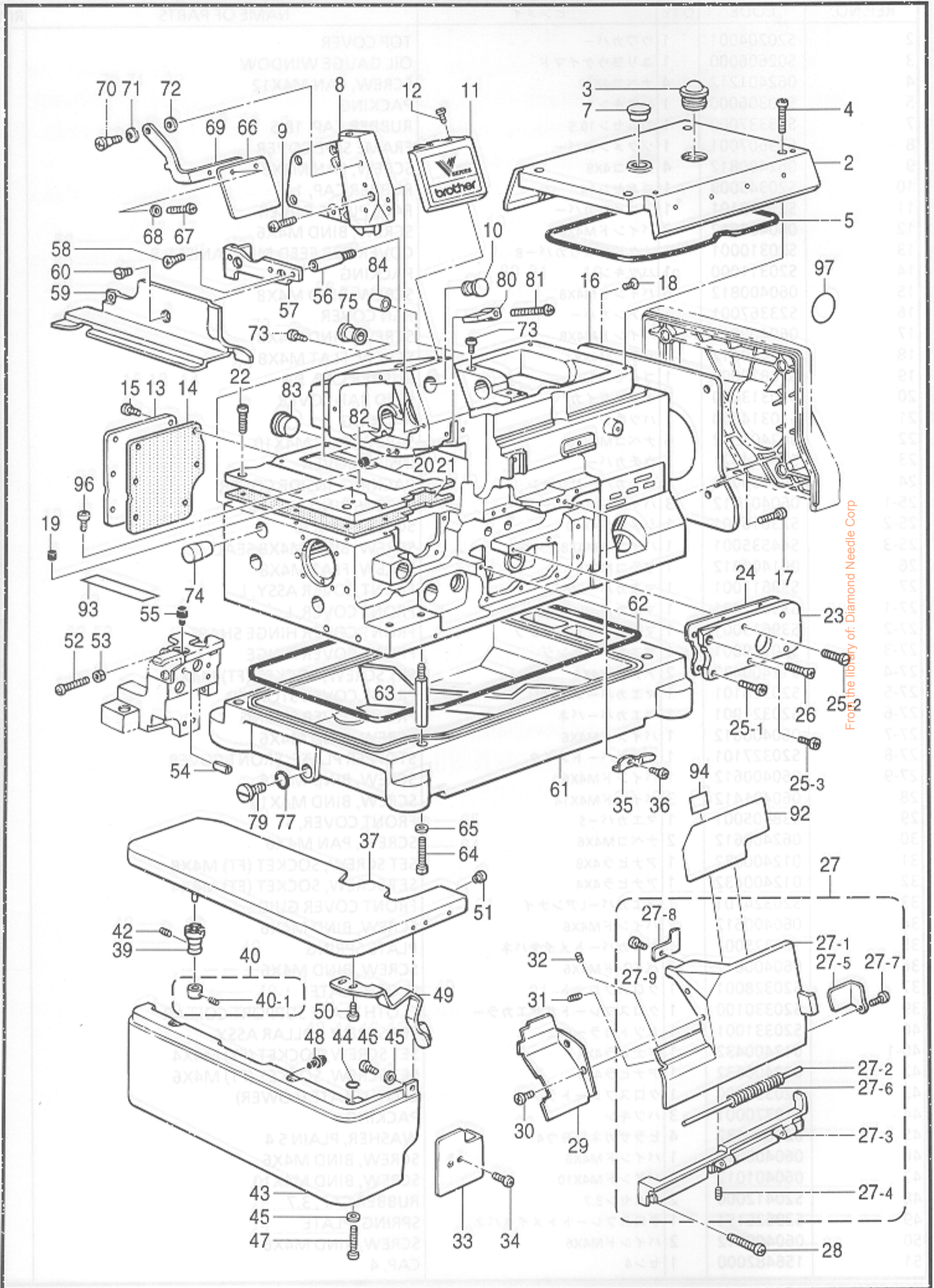

A. 主体関係 / Machine body / Maschinengehäuse / Corps de la machine / Cuerpo de la máquina

Mecanismo del cigüeñal

Isneugio leb omainsoem

REF.NO.	CODE	Q'TY	ヒンメイ	NAME OF PARTS	RM
52	062401212	1	ナベコ4X12	SCREW, PAN M4X12	
53	021400212	1	2シユナツト4	NUT, 2 M4	
54	047602042	1	スプリングピン6X20	PIN, SPRING ROLL 6X10	
55	S20412000	1	ゴムセン3.7	RUBBER CAP, 3.7	
56	S20208001	2	スタツド4	STUD, 4	
57	S20207101	1	ヌノアンナイトリツケイタ	CLOTH GUIDE SET PLATE	
58	061400812	2	サラコM4X8	SCREW, FLAT M4X8	
59	S20337001	1	クロスプレートヌノアンナイ	CLOTH GUIDE	
60	S23418002	2	シメネジ4X5	SCREW, M4X5	
61	S20338200	1	アブラウケ	OIL PAN	
62	S20339000	1	ハツキン	PACKING	
63	S23350001	4	ホンタイシチユウ	MACHINE BODY LEG	
64	017501212	4	ボルト5X12	BOLT, M5X12	
65	S23351001	4	ザガネ	WASHER	
66	S00075000	1	アイガード	EYE GUARD	
67	060350812	2	バインド35X8	SCREW, BIND M3.5X8	
68	025350332	2	ヒラザガネダイ3.5	WASHER, PLAIN L 3.5	
69	S20340001	1	アイガードササエイタ	EYE GUARD SUPPORT PLATE	
70	S20342001	1	ダンネジ4	SHOULDER SCREW, M4	
71	146598001	1	バネザガネ	WASHER, SPRING	
72	025050132	1	ヒラザガネシヨウ5	WASHER, PLAIN S 5	
73	S30517101	5	ナベコシール6X10	SCREW, PAN M6X10 SEAL	
74	S20344009	1	ゴムセン16	RUBBER CAP, 16	
75	S20345009	1	ゴムセン14	RUBBER CAP, 14	
77	081009070	1	OリングP9	O RING, P9	
79	S23357001	1	シメネジ10	SCREW, M10	
80	S20346000	1	ハリボウアブラウケ	NEEDLE BAR OIL RESERVOIR	
81	062401612	1	ナベコM4X16	SCREW, PAN M4X16	
82	S20878000	1	ゴムセン5.3	RUBBER CAP, 5.3	
83	S23337009	1	ゴムセン18.5	RUBBER CAP, 18.5	
84	S07477009	1	ゴムリング	RUBBER RING	
92	S25182001	1	<5本糸用> イトトオシセツメイラベルD	<FOR "5 THREADS"> THREADING DIAGRAM LABEL (D)	
92	S25183001	1	<4本糸用> イトトオシセツメイラベルE	<FOR "4 THREADS"> THREADING DIAGRAM LABEL (E)	
92	S31867001	1	<6本糸用> イトトオシセツメイラベルF	<FOR "6 THREADS"> THREADING DIAGRAM LABEL (F)	
93	S25184001	1	DLイトトオシセツメイラベルF	THREADING DIAGRAM LABEL DL	
94	S44821001	1	セイソウシジラベル	LABEL, CLEANING	
96	060400512	1	バインドM4X5	SCREW, BIND M4X5	
97	S43453001	1	フィルタコウカンシジラベル	LABEL, CLEANING FILTER	

From the library of: Diamond Needle Corp

B. 駆動軸関係 / Driving shaft mechanism / Kurbelwelle / Mécanisme de vilebrequin / Mecanismo del cigüeñal

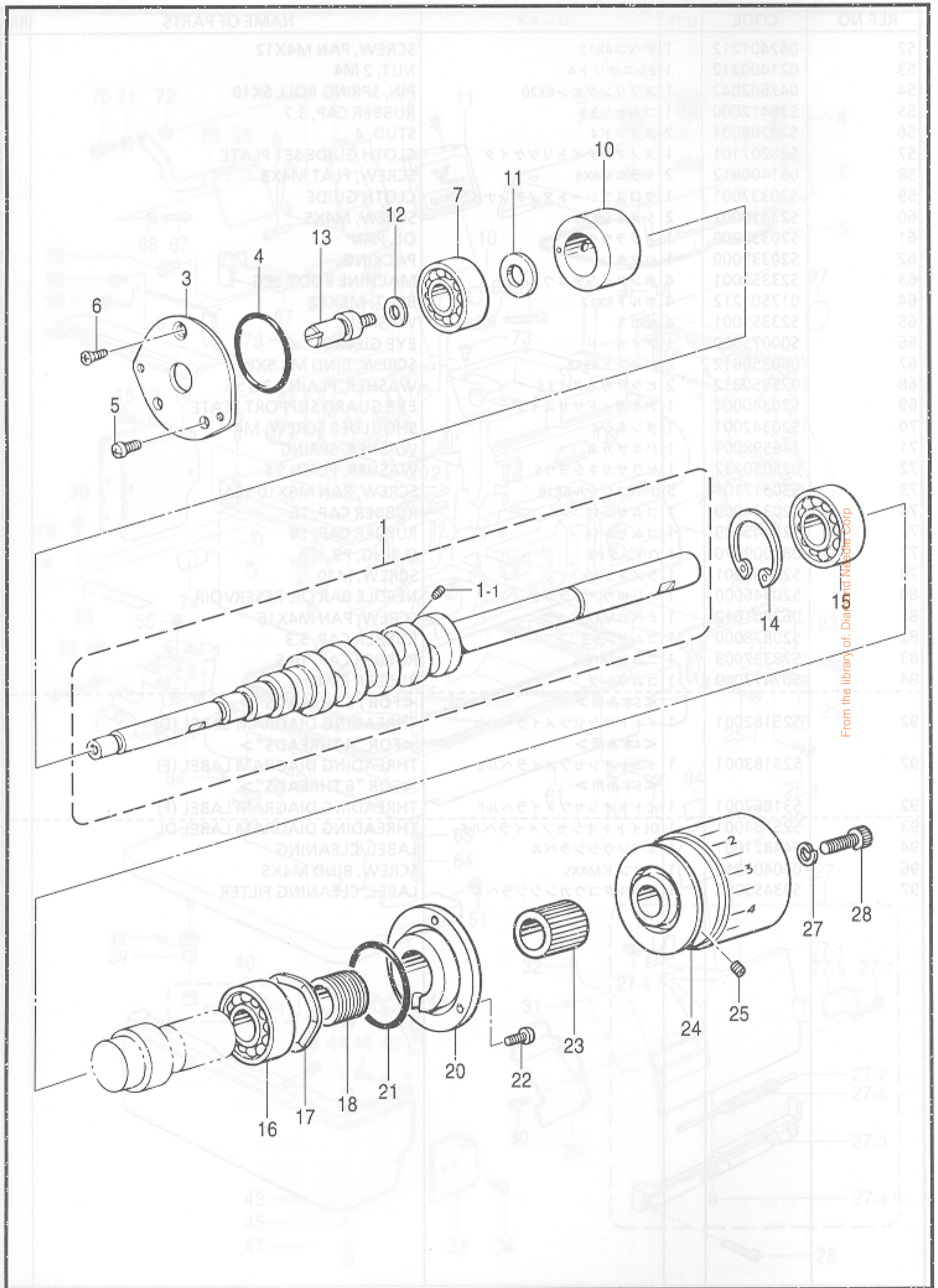

B. 駆動軸関係 / Crankshaft mechanism / Kurbelwelle / Mécanisme de vilebrequin / 糸縫機
 Mecanismo del cigüeñal / aigulle / Mecanismo de la aguja / bobbin

REF.NO.	CODE	Q'TY	品名	NAME OF PARTS	RM
1	S46923001	1	クドウジクQネジツキ	CRANKSHAFT, Q W/SCREW	
1-1	S25530001	1	アナクボミ2.5X4	SET SCREW, SOCKET M2.5X14	
3	S39629021	1	ベアリングフタ	BEARING CAP	
4	081031870	1	Oリング S31.5	O RING S31.5	
5	062400812	2	ナベコ4X8	SCREW, PAN M4X8	
6	061400812	1	サラコM4X8	SCREW, FLAT M4X8	
7	072600000	1	タマジクウケ6000	BALL BEARING, 6000	
10	S39630000	1	クドウジクメタル	CRANK SHAFT BUSH	
11	S20356001	1	ヒラザガネ10	WASHER, PLAIN 10	
12	155559001	1	ヒラザガネ	WASHER, PLAIN	
13	S46900001	1	ニジユウカンテンビンジク	D-CHAIN STITCH THR.	
14	048400242	1	トメワアナヨウC40	RETAINING RING, C40	
15	076203000	1	タマジクウケ6203	BALL BEARING, 6203	
16	S27868001	1	タマジクウケ6203V	BALL BEARING, 6203V	
17	S20361001	1	ナミバネ	SPRING, WAVE	
18	S20362151	1	クドウジクオイルキリ	CRANK SHAFT OIL REJECTOR	
20	S39631000	1	ベアリングオサエ	BEARING PRESSER	
21	S20353000	1	Oリング	O RING	
22	062401012	3	ナベコM4X10	SCREW, PAN M4X10	
23	S34326000	1	ファンブツシュ	BUSHING, FAN	
24	S39565101	1	プーリ	PULLEY	
25	012060632	2	アナヒラ6X6	SET SCREW, SOCKET (FT) M6X6	
27	028060242	1	バネザガネ2-6	WASHER, SPRING 2-6	
28	018062532	1	アナホルト6X25	BOLT, SOCKET M6X25	
12			ニードルクランプ	NEEDLE CLAMP	
12-1	146427001		セットメネジ3.18X7	SET SCREW, SOCKET (FT) SM3.18	
13			ニードルハリ DCK27	NEEDLE, DCK27	
14	S39649021		ハリイタササエ	NEEDLE PLATE SUPPORT BRACKET	
15	018062532	2	アナホルト6X25	BOLT, SOCKET (FT) M6X25	
16	S39650051		ハリイタササエ	NEEDLE PLATE SUPPORT BRACKET	
17	062401012	3	ナベコM4X10	SCREW, PAN M4X10	
18	S20413051		ハリイタササエ	SUPPORT BRACKET, PLATE SUPPORT	
19	062400612	2	ナベコM4X6	SCREW, PAN M4X6	
20	S20414001		サポートプレート	SUPPORT PLATE, B NEEDLE	
21	S23418002	2	セットメネジ4X5	SET SCREW, SOCKET (FT) M4X5	
22	S20415101		ニードルガード	NEEDLE GUARD, MOVABLE	
23	S20416101		ボルト3.5X10	BOLT, SOCKET (FT) M3.5X10	
24	S20418051		ニードルガード	NEEDLE GUARD, F	
25	S23456101	2	ナベコ2.5X6	SCREW, PAN M2.5X6	
26	S38306051		ニジユウカンハリウケF	D-CHAIN STITCH NEEDLE GUARD, F	
27	062395312	1	ナベコ3.5X8	SCREW, PAN M3.5X8	
28	S38317001	1	ニジユウカンハリウケB	CHAIN STITCH NEEDLE GUARD, B	
29	062400812	2	ナベコ4X8	SCREW, PAN M4X8	
30	S39654051		ハリウケブラケット	NEEDLE GUARD BRACKET	
31	062401012	1	ナベコM4X10	SCREW, PAN M4X10	
32			ニードルプレート	NEEDLE PLATE	
33	100032003		セットメネジ4.37	SET SCREW, SOCKET (FT) SM4.37	

From the library of: Diamond Needle Corp

C. 針棒關係 / Needle bar mechanism / Nadelstangenvorrichtung / Mécanisme de la barre à
aiguille / Mecanismo de la barra de aguja

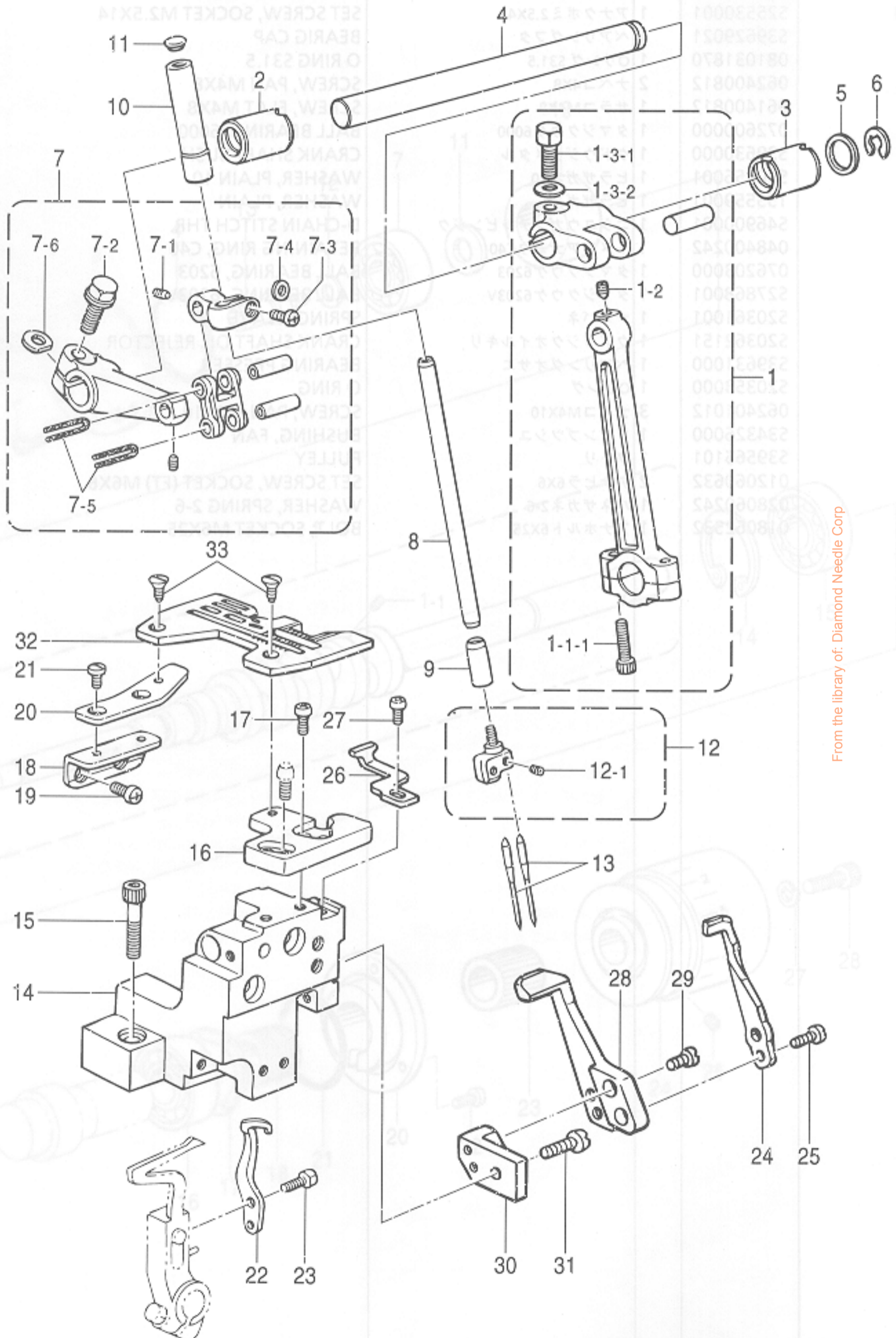

From the library of: Diamond Needle Corp

C. 針棒関係 / Needle bar mechanism / Nadelstangenvorrichtung /
 Mécanisme de la barre à aiguille / Mecanismo de la barra de aguja

REF.NO.	CODE	Q'TY	ヒンメイ	NAME OF PARTS	RM
1	S46931001	1	<ハイリフト用> ハリクランクロッドクミH	<FOR HIGH-LIFT> N-DRIVING CRANK ROD ASSY, H	
1	S46932001	1	<超ハイリフト用> ハリクランクロッドクミE	<FOR EXTRA HIGH-LIFT> N-DRIVING CRANK ROD ASSY, E	
1-1-1	018401622	2	アナボルト4X16	BOLT, SOCKET M4X16	
1-2	S23342001	1	アナトガリ4X5	SET SCREW, SOCKET (CN) M4X5	
1-3-1	017061612	1	ボルト6X16	BOLT, M6X16	
1-3-2	118735002	1	ザガネ	WASHER	
2	S39644021	1	ハリジクメタルL	NEEDLE SHAFT BUSH, L	
3	S39645021	1	ハリジクメタルR	NEEDLE SHAFT BUSH, R	
4	S39646021	1	ハリジク	NEEDLE SHAFT	
5	S39647000	1	ザガネ	WASHER	
6	146293001	1	トメワE10	RETAINING RING, E10	
7	S20386101	1	ハリボウダキクミ	NEEDLE BAR CLAMP ASSY	
7-1	S23342001	2	アナトガリ4X5	SET SCREW, SOCKET (CN) M4X5	
7-2	S46899001	1	ザガネツキボルト6X16	BOLT, (S/P WASHER) M6X16	
7-3	062350812	1	ナベコ3.5X8	SCREW, PAN M3.5X8	
7-4	S20391001	1	スヘーサ	SPACER	
7-5	S20392000	2	フェルト	FELT	
7-6	155162001	1	スヘーサ	SPACER	
8	S20393101	1	ハリボウ	NEEDLE BAR	
9	S39648021	1	ハリボウメタルD	NEEDLE BAR BUSH, D	
10	S39571021	1	ハリボウメタルU	NEEDLE BAR BUSH, U	
11	104450101	1	ゴムセン8	RUBBER CAP, 8	
12	※	1	ハリドメクミ	NEEDLE CLAMP ASSY	
12-1	146427001	2	アナトメネジ3.18クボミ	SET SCREW, SOCKET (CP) SM3.18	
13	※	2	ミシンハリ DCX27	NEEDLE, DCX27	
14	S39649021	1	ハリイタササエダイ	NEEDLE PLATE SUPPORT BRACKET	
15	018062532	2	アナボルト6X25	BOLT, SOCKET M6X25	
16	S39650051	1	ハリイタササエイタF	NEEDLE PLATE SUPPORT, F	
17	062401012	2	ナベコM4X10	SCREW, PAN M4X10	
18	S20413051	1	ハリイタササエイタBササエ	SUPPORT, B N-PLATE SUPPORT	
19	062400612	2	ナベコM4X6	SCREW, PAN M4X6	
20	S20414001	1	ハリイタササエイタB	SUPPORT PLATE, B NEEDLE PLATE	
21	S23418002	2	シメネジ4X5	SCREW, M4X5	
22	S20415101	1	イドウハリウケ	NEEDLE GUARD, MOVABLE	
23	S20416101	1	ボルト3.5X10	BOLT, M3.5X10	
24	S20418051	1	オーバーハリウケF	NEEDLE GUARD, F	
25	S23456101	2	ナベコ2.5X6	SCREW, PAN M2.5X6	
26	S38306051	1	ニジユウカンハリウケF	CHAIN STITCH NEEDLE GUARD, F	
27	062350812	1	ナベコ3.5X8	SCREW, PAN M3.5X8	
28	S38307001	1	ニジユウカンハリウケB	CHAIN STITCH NEEDLE GUARD, B	
29	062300812	2	ナベコ3X8	SCREW, PAN M3X8	
30	S39654051	1	ハリウケブラケット	NEEDLE GUARD BRACKET	
31	062401012	1	ナベコM4X10	SCREW, PAN M4X10	
32	※	1	ハリイタ	NEEDLE PLATE	
33	100032003	2	サラネジ4.37	SCREW, FLAT SM4.37	
34	062350612	2	ナベコM3.5X6	SCREW, PAN M3.5X6	
35	S23364000	1	アーム	ARM	

From the library of: Diamond Needle Corp

D. 押工関係 / Presser foot mechanism / Stoffdrückerfuß / Mécanisme de pied presseur / Mecanismo de la prensa tela

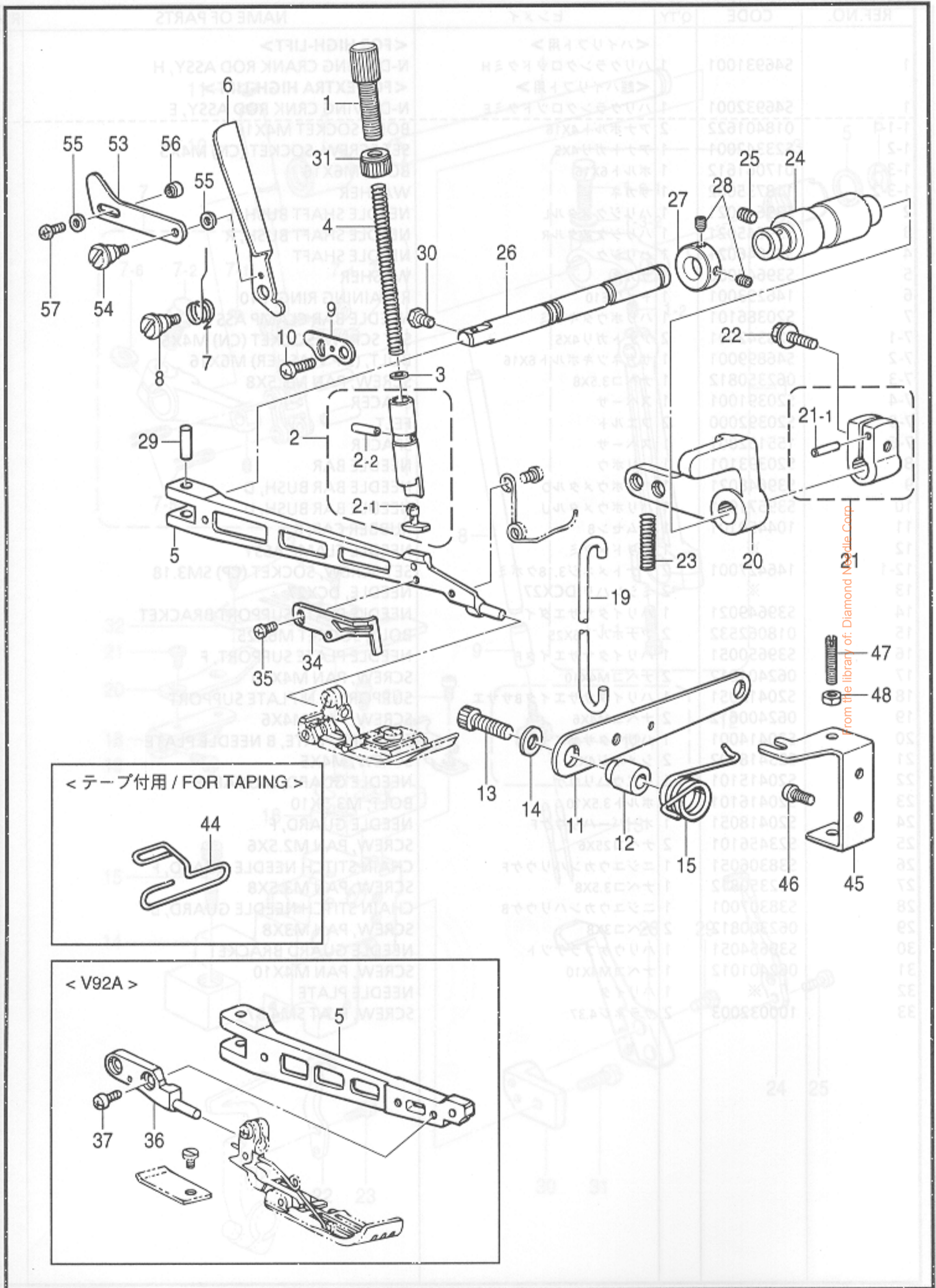

D. 押工関係 / Presser foot mechanism / Stoffdrückerfuß / Mécanisme de pied presseur /
Mecanismo de la prensa tela

REF.NO.	CODE	Q'TY	ヒンメイ	NAME OF PARTS	RM
1	S20472001	1	オサエチヨウセツネジ	ADJUST SCREW	
2	S46887001	1	オサエボウクミ	PRESSER BAR ASSY	
2-1	S39577000	1	オサエクツシヨン	CUSHION	
2-2	047301642	1	スプリングピンAW3	PIN, SPRING ROLL AW3	
3	105161004	1	ザガネ	WASHER	
4	S20477001	1	オサエバネ	PRESSER SPRING	
6	S46840001	1	オサエテアゲ	PRESSER BAR LIFTER	
7	S39660001	1	オサエテアゲバネ	PRESSER BAR LIFTER SPRING	
8	S39661001	1	ダンネジ4	SHOULDER SCREW, M4	
9	S39662001	1	シユオサエウデストツバ	MAIN PRESSER ARM STOPPER	
10	060400612	1	バインドM4X6	SCREW, BIND M4X6	
11	S39663021	1	オサエアジアゲレバー	PRESSER FOOT LIFTER LEVER	
12	S39664001	1	オサエアジアゲレバーカラー	COLLAR	
13	018062532	1	アナホルト6X25	BOLT, SOCKET M6X25	
14	025060332	1	ヒラザガネダイ6	WASHER, PLAIN L 6	
15	S39665001	1	オサエアジアゲレバーバネ	SPRING	
19	S20485001	1	オサエアゲリンク	PRESSER BAR LIFTER LINK	
20	S20209001	1	オサエアゲレバー	PRESSER BAR LIFTER LEVER	
21	S46849001	1	オサエアゲウデクミ	PRESSER BAR LIFTER ARM ASSY	
21-1	047401642	1	スプリングピンAW4	PIN, SPRING ROLL AW4	
22	S46899001	1	ザガネツキボルト6X16	BOLT, (S/P WASHER) M6X16	
23	S20489001	1	オサエアゲレバーバネ	SPRING, PRESSER LIFTER LEVER	
24	S46839000	1	オサエウデジクメタル	PRESSER ARM SHAFT BUSH	
25	012060632	1	アナヒラ6X6	SET SCREW, SOCKET (FT) M6X6	
26	S39671101	1	オサエウデジク	PRESSER ARM SHAFT	
27	S39733001	1	セツトカラー	SET SCREW COLLAR	
28	012400432	2	アナヒラ4X4	SET SCREW, SOCKET (FT) M4X4	
29	S39672001	1	オサエウデピン	PRESSER ARM PIN	
30	S46903001	1	アタマツキトメネジ4X5	SET SCREW, M4X5	
31	S23341009	1	チヨウセツネジツマミナツト	NUT	
45	S23349001	1	レバーチヨウセツイタ	LEVER ADJUSTING PLATE	
46	060400812	2	バインドM4X8	SCREW, BIND M4X8	
47	011502012	2	トメネジ5X20ヒラ	SET SCREW, (FT) M5X20	
48	021500312	2	3シユナツト5	NUT, 3 M5	
53	S46841001	1	ウワオクリアゲリンク	LINK	
54	S46842001	1	ダンネジ4	SHOULDER SCREW, M4	
55	158722002	2	ザガネ4.2	WASHER, PLAIN 4.2	
56	S46843001	1	カラー	COLLAR	
57	062401612	1	ナベコM4X16	SCREW, PAN M4X16	
5	S46889001	1	シユオサエウデ	MAIN PRESSER ARM	
34	S37070121	1	フィンガーガードV	FINGER GUARD, V	
35	060300412	1	バインドM3X4	SCREW, BIND M3X4	
	S150755001	1	<V92A>	SCREW, SM3.18	
5	S46908001	1	シユオサエウデ	MAIN PRESSER ARM	
36	S20298001	1	ナカオサエウデ	PRESSER ARM	
37	062350612	2	ナベコM3.5X6	SCREW, PAN M3.5X6	
	S19379001	1	<テープ付け用>	<FOR TAPING>	
44	S23364000	1	テープアンナイ	TAPE GUIDE	
	S148294001	1	アタトメネジ3.57X7ボルト	SET SCREW, SOCKET (CP) SM3.57	
	S062670712	1	ナベコ3.57-40X7	SCREW, PAN SM3.57-40X7	
	S19535001	1	オサエ8ホシヨイタ	PRESSER FOOT (B) SUPPORT PLATE	
	S140530002	1	シメネジ2.38	SCREW, SM2.38	

From the library of: Diamond Needle Corp

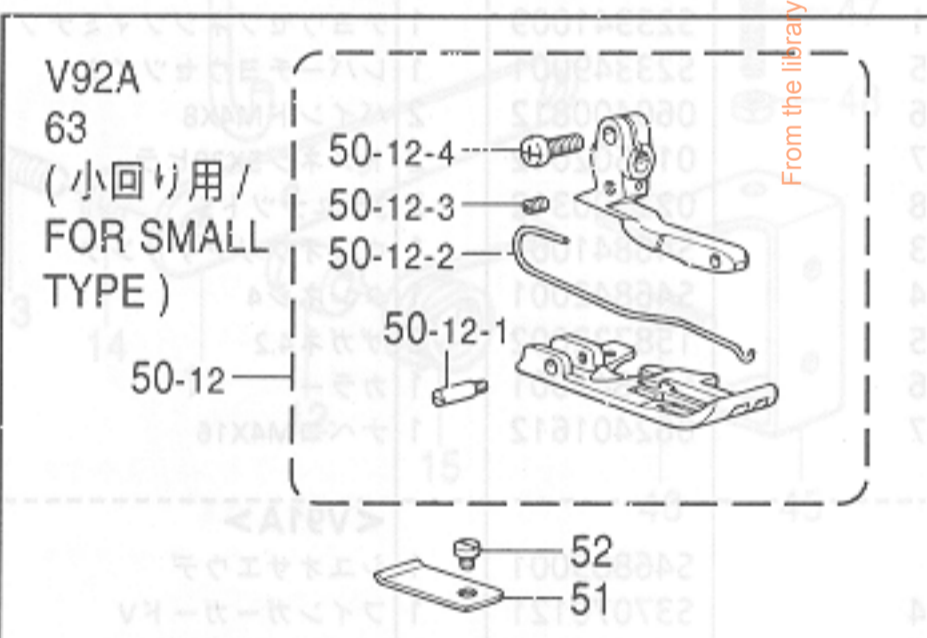
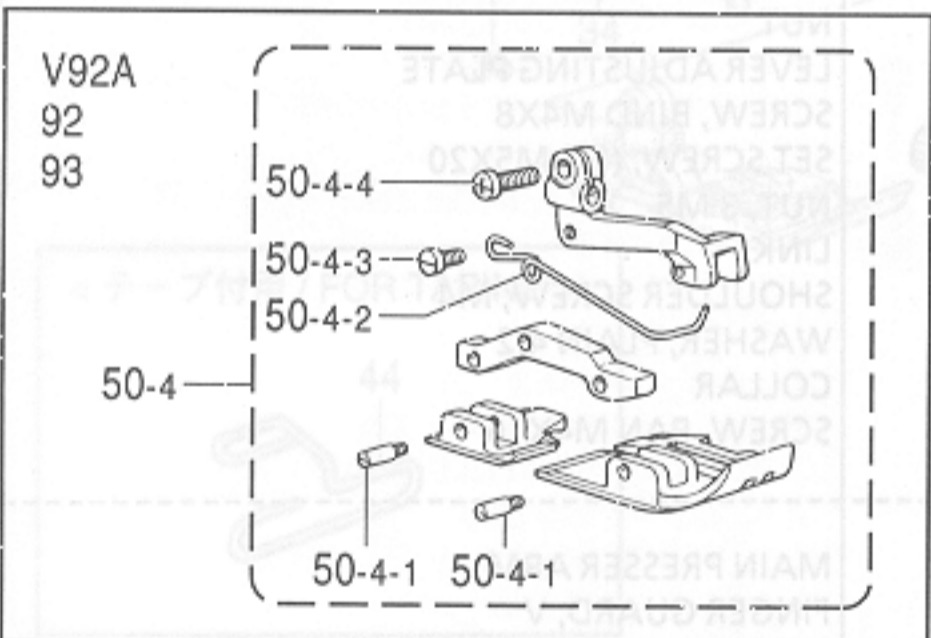
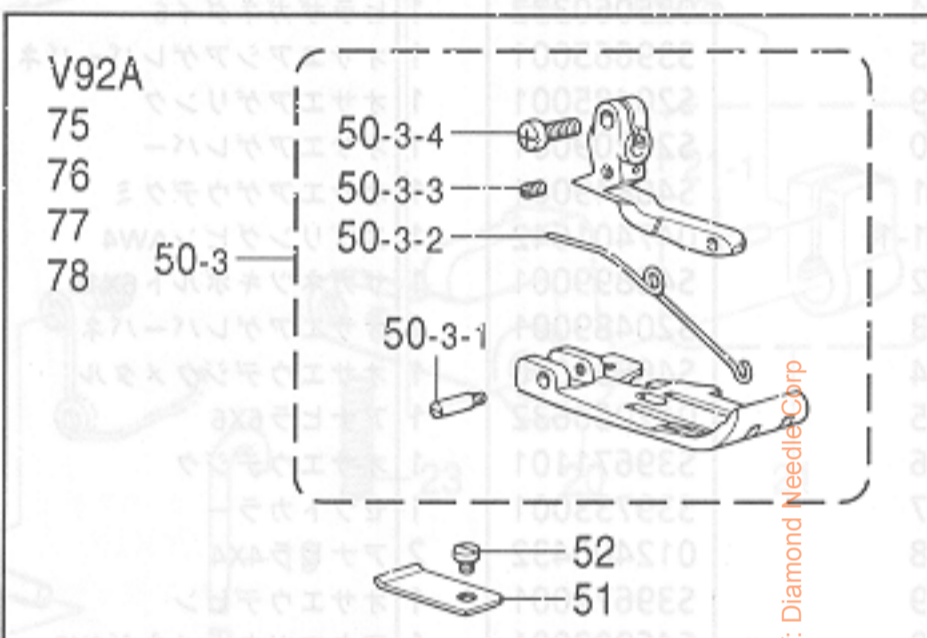
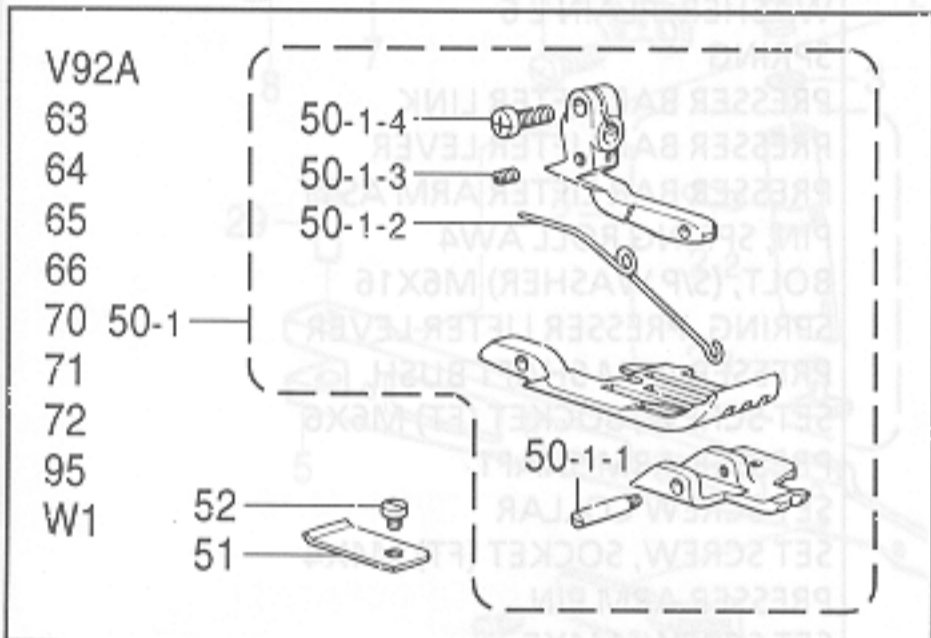
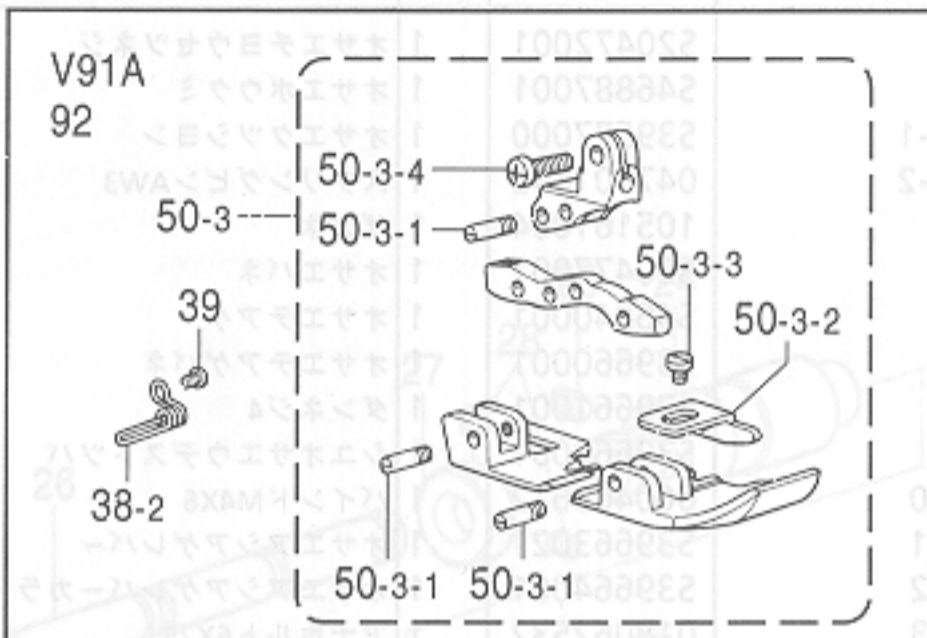
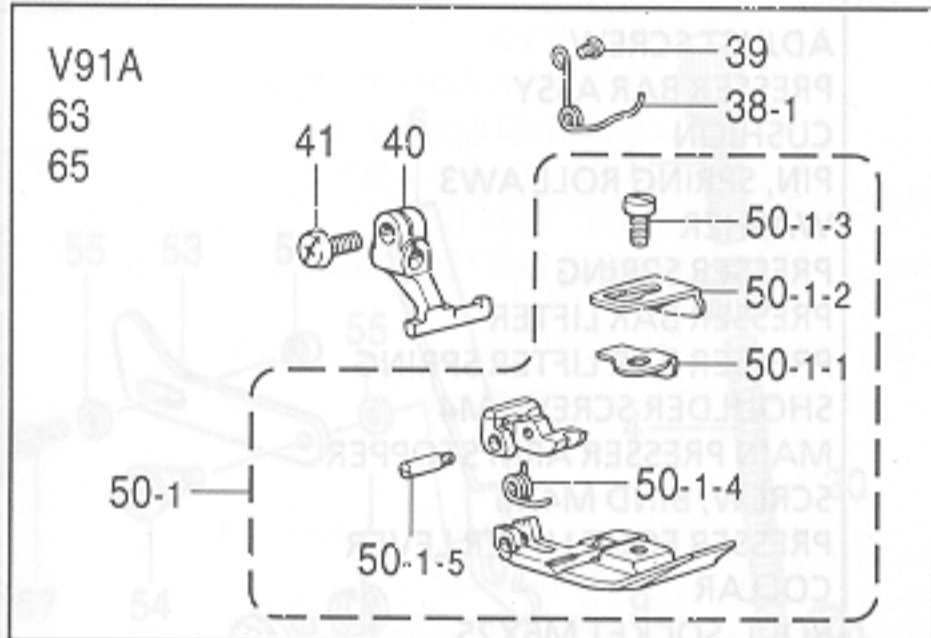

From the library of: Diamond NeedleCorp

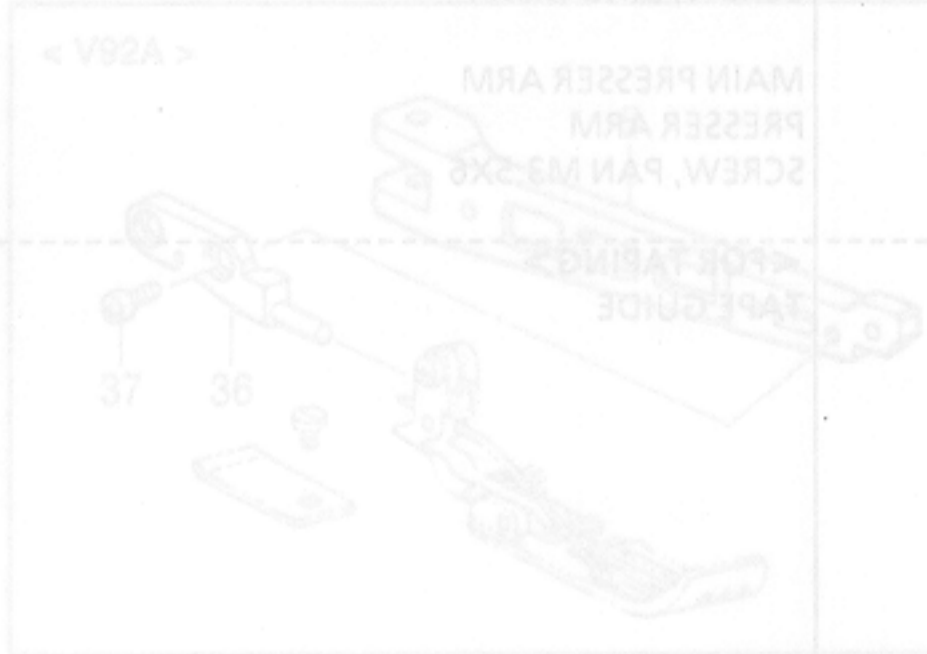

D. 押工関係 / Presser foot mechanism / Stoffdrückerfuß / Mécanisme de pied presseur / Mecanismo de la prensa tela

REF.NO.	CODE	Q'TY	ヒンメイ	NAME OF PARTS	RM
	S20496101	1	V91A < 63,65 >	ECCENTRIC LINK ASSY	
50-1	※	1	オサエクミ	PRESSER FOOT ASSY	
50-1-1	S19368001	1	オサエトリツケイタ	PRESSER FOOT PLATE	
50-1-2	S19367001	1	オサエF	PRESSER FOOT, F	
50-1-3	106640001	1	シメネジ3.18	SCREW, SM3.18	
50-1-4	S19369001	1	オサエBネジリバネ	SPRING, TWIST	
50-1-5	S19346001	1	シテンネジ	SCREW	
38-1	S30140001	1	オサエネジリバネ	SPRING, TWIST	
39	060300612	1	バインドM3X6	SCREW, BIND M3X6	
40	S20788001	1	フクオサエウデ	SUB PRESSER ARM	
41	062670712	1	ナベコ357-40X7	SCREW, PAN SM3.57-40X7	
			V91A < 92 >	FEED ARM ASSY	
50-3	※	1	オサエクミ	PRESSWE FOOT ASSY	
50-3-1	S19311101	3	オサエササエネジ	PRESSWE FOOT SUPPORT SCREW	
50-3-2	S19340001	1	オサエF	PRESSER FOOT, F	
50-3-3	106640001	1	シメネジ3.18	SCREW, SM3.18	
50-3-4	062670712	1	ナベコ357-40X7	SCREW, PAN SM3.57-40X7	
38-2	S20115001	1	オサエネジリバネ	SPRING, TWIST	
39	060300612	1	バインドM3X6	SCREW, BIND M3X6	
			V92A < 63,65,69,71 >	FEED SHAFT BUSH	
50-1	※	1	オサエクミ	PRESSWE FOOT ASSY	
50-1-1	S19379001	1	シテンネジ	SCREW	
50-1-2	S21017001	1	オサエネジリバネ	SPRING, TWIST	
50-1-3	148294001	1	アナトメネジ3.57クボミ	SET SCREW, SOCKET (CP) SM3.57	
50-1-4	062670712	1	ナベコ357-40X7	SCREW, PAN SM3.57-40X7	
51	S19535001	1	オサエBホジヨイタ	PRESSER FOOT (B) SUPPORT PLATE	
52	140530002	1	シメネジ2.38	SCREW, SM2.38	
			V92A < 75,77 >	WASHER	
50-3	※	1	オサエクミ	PRESSWE FOOT ASSY	
50-3-1	S19346001	1	シテンネジ	SCREW	
50-3-2	S21017001	1	オサエネジリバネ	SPRING, TWIST	
50-3-3	148294001	1	アナトメネジ3.57クボミ	SET SCREW, SOCKET (CP) SM3.57	
50-3-4	062670712	1	ナベコ357-40X7	SCREW, PAN SM3.57-40X7	
51	S19535001	1	オサエBホジヨイタ	PRESSER FOOT (B) SUPPORT PLATE	
52	140530002	1	シメネジ2.38	SCREW, SM2.38	
			V92A < 92 >	FEED BAR SLIDE BLOCK	
50-4	※	1	オサエクミ	PRESSWE FOOT ASSY	
50-4-1	S19311101	3	オサエササエネジ	PRESSWE FOOT SUPPORT SCREW	
50-4-2	S19399001	1	オサエネジリバネ	SPRING, TWIST	
50-4-3	150755001	1	シメネジ3.18	SCREW, SM3.18	
50-4-4	062670712	1	ナベコ357-40X7	SCREW, PAN SM3.57-40X7	
			V92A < 63 >	FEED BAR SLIDE BLOCK SHAFT	
50-12	※	1	オサエクミ	PRESSWE FOOT ASSY	
50-12-1	S19379001	1	シテンネジ	SCREW	
50-12-2	S21017001	1	オサエネジリバネ	SPRING, TWIST	
50-12-3	148294001	1	アナトメネジ3.57クボミ	SET SCREW, SOCKET (CP) SM3.57	
50-12-4	062670712	1	ナベコ357-40X7	SCREW, PAN SM3.57-40X7	
51	S19535001	1	オサエBホジヨイタ	PRESSER FOOT (B) SUPPORT PLATE	
52	140530002	1	シメネジ2.38	SCREW, SM2.38	
				DIFFERENTIAL FEED ADJUST LINK	
				SCREW, M5	
				DIFFERENTIAL LINK LEVER	
				BOLT, SOCKET M6X14	

From the library of: Diamond Needle Corp

E. 送り関係 / Feed mechanism / Transportvorrichtung / Mécanisme de l'entraînement
 / Mecanismo de la alimentación

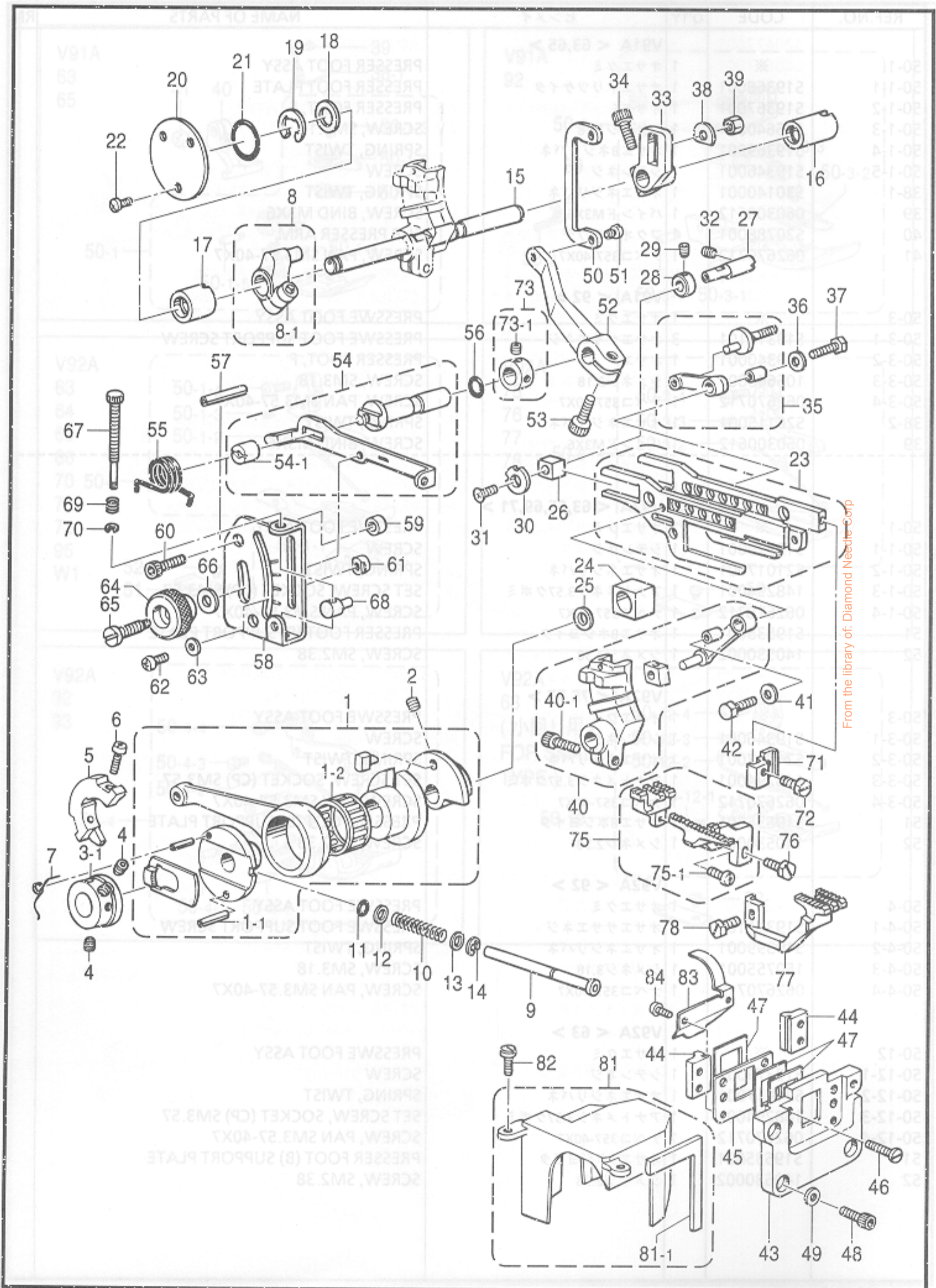

From the library of: Diamond Needle Corp

E. 送り関係 / Feed mechanism / Transportvorrichtung / Mécanisme de l'entraînement / Mecanismo de la alimentación

REF.NO.	CODE	Q'TY	ヒンメイ	NAME OF PARTS	RM
1	S20496101	1	ヘンシンリンクミ	ECCENTRIC LINK ASSY	
1-1	047250842	1	スプリングピンAW2.5	PIN, SPRING ROLL AW2.5	
1-2	S20500001	1	ニードルジクウケ24 (赤)	NEEDLE BEARING 24 RED	
1-2	S20500002	1	ニードルジクウケ24 (青)	NEEDLE BEARING 24 BLUE	
1-2	S20500003	1	ニードルジクウケ24 (白)	NEEDLE BEARING 24 WHITE	
2	012060632	2	アナヒラ6X6	SET SCREW, SOCKET (FT) M6X6	
3-1	S20507001	1	ラチエツト	RATCHET	
4	012060632	2	アナヒラ6X6	SET SCREW, SOCKET (FT) M6X6	
5	S23615001	1	バランスウエイト	BALANCE WEIGHT	
6	062401012	2	ナベコM4X10	SCREW, PAN M4X10	
7	S23458101	1	ラチエツトトメネジリバネ	SPRING, TWIST	
8	S39589021	1	オクリウテクミ	FEED ARM ASSY	
8-1	018061632	1	アナボルト6X16	BOLT, SOCKET M6X16	
9	S39674001	1	オクリチヨウセツボタンジク	FEED ADJUST SHAFT	
10	S39675001	1	ボタンジクバネ	SPRING	
11	081005070	1	OリングP5	O RING, P5	
12	025710232	1	ヒラザガネチユウ4.76	WASHER, PLAIN M 4.76	
13	025710232	1	ヒラザガネチユウ4.76	WASHER, PLAIN M 4.76	
14	048040342	1	トメワE4	RETAINING RING, E4	
15	S39676121	1	オクリジク	FEED SHAFT	
16	S39677021	1	メタル11.11-17	BUSH, 11.11-17	
17	S39678021	1	オクリジクメタルL	FEED SHAFT BUSH, L	
18	S30562000	1	ザガネ	WASHER	
19	048090342	1	トメワE9	RETAINING RING, E9	
20	S39679001	1	オクリジクメタルLフタ	FEED SHAFT BUSH CAP, L	
21	081020070	1	OリングP20	O RING, P20	
22	060400612	3	バインドM4X6	SCREW, BIND M4X6	
23	S46891001	1	オクリダイクミ	FEED BAR ASSY	
24	S38312050	1	ジヨウゲオクリカクゴマ	FEED LIFTING SLIDE BLOCK	
25	142628001	2	スイハイオクリクランクリング	FEED ROCK CRANK RING	
26	S39683000	1	オクリダイカクゴマ	FEED BAR SLIDE BLOCK	
27	S39684021	1	オクリダイカクコマジク	FEED BAR SLIDE BLOCK SHAFT	
28	S39685001	1	セットカラー	SET SCREW COLLAR	
29	012400432	1	アナヒラ4X4	SET SCREW, SOCKET (FT) M4X4	
30	S20530001	1	ザガネ	WASHER	
31	004350812	1	+サラコ35X8	SCREW, FLAT M3.5X8	
32	012400832	1	アナヒラ4X8	SET SCREW, SOCKET (FT) M4X8	
33	S42042021	1	シユオクリウデ	MAIN FEED ARM	
34	018061632	1	アナボルト6X16	BOLT, SOCKET M6X16	
35	S39773001	1	シユオクリリンククミ	MAIN FEED LINK ASSY	
36	S39690021	1	ザガネ	WASHER	
37	S23360001	1	ボルト5X15	BOLT, M5X15	
38	S02573000	1	ザガネ	WASHER	
39	S39691001	1	ナツト5	NUT, M5	
40	S39769051	1	サドウオクリウデリンククミ	DIFF. FEED ARM LINK ASSY	
40-1	018061632	1	アナボルト6X16	BOLT, SOCKET M6X16	
41	S39690021	1	ザガネ	WASHER	
42	S23360001	1	ボルト5X15	BOLT, M5X15	
43	S20523000	1	オクリダイアンナイササエ	FEED BAR GUIDE SUPPORT	
44	S20524000	2	オクリダイアンナイ	FEED BAR GUIDE	
45	S20525001	1	ボウジンイタササエ	FRAGMENT PROTECTOR PLATE	
46	S20740101	4	シメネジ4X10シール	SCREW, SEAL M4X10	
47	S20526000	3	ボウジンイタ	FRAGMENT PROTECTOR PLATE	
48	S43916001	4	アナボルト4X8シール	SCREW, SEAL M4X10	
49	025040132	4	ヒラザガネシヨウ4	WASHER, PLAIN S 4	
50	S39692021	1	サドウチヨウセツリンク	DIFFERENTIAL FEED ADJUST LINK	
51	S20543101	1	シメネジ5	SCREW, M5	
52	S20544000	1	サドウリンクレバー	DIFFERENTIAL LINK LEVER	
53	018061432	1	アナボルト6X14	BOLT, SOCKET M6X14	

From the library of: Diamond Needle Corp

E . 送り関係 / Feed mechanism / Transportvorrichtung / Mécanisme de l'entraînement
 / Mecanismo de la alimentación

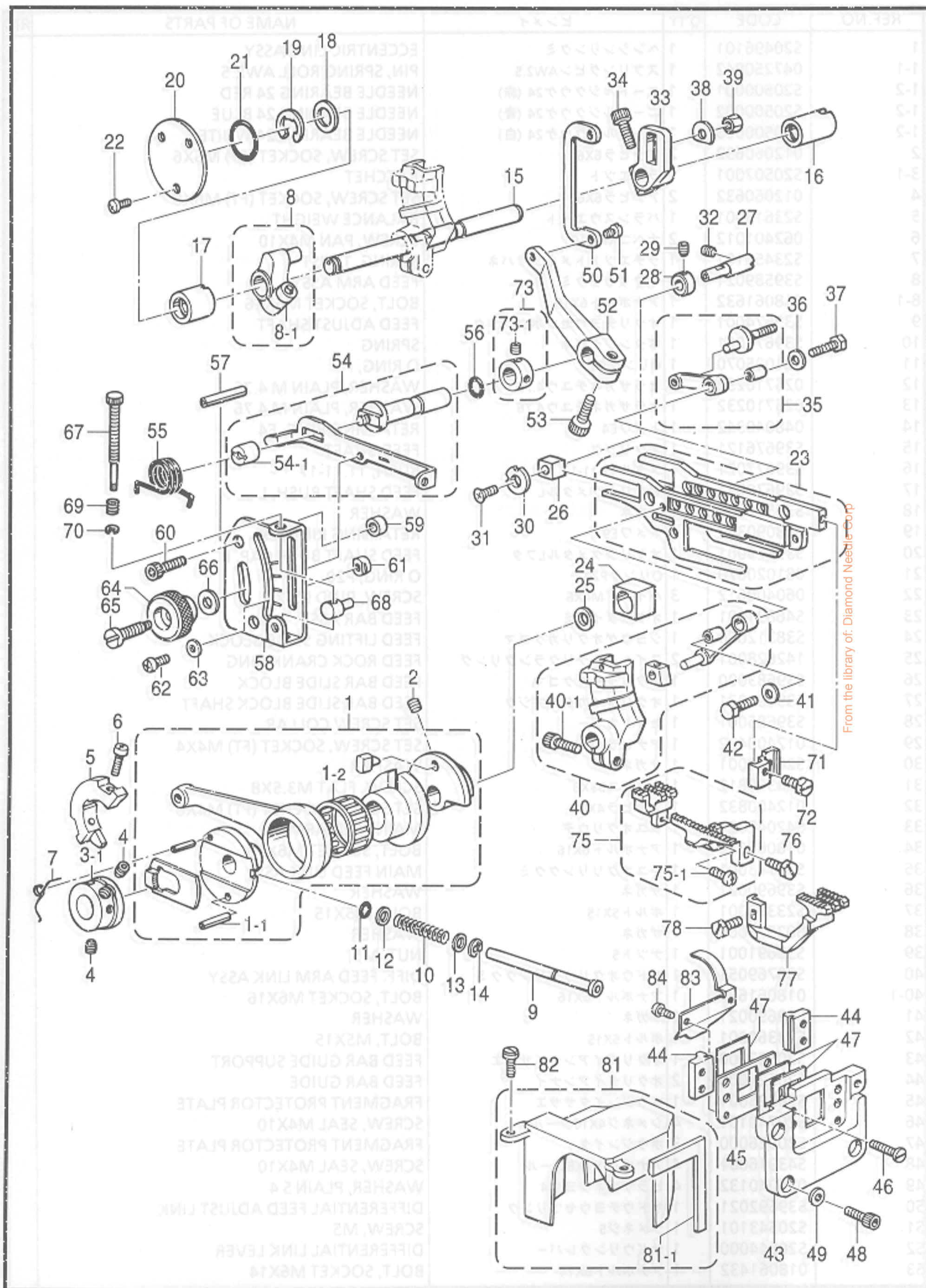

E. 送り関係 / Feed mechanism / Transportvorrichtung / Mécanisme de l'entraînement / Mecanismo de la alimentación

REF.NO.	CODE	Q'TY	ヒンメイ	NAME OF PARTS	RM
54	S39593021	1	サドウチヨウセツレバークミ	DIFF. FEED ADJUST LEVER ASSY	
54-1	S39596021	1	マルナツト6	NUT, ROUND M6	
55	S20547001	1	レバーバネ	SPRING	
56	081005670	1	OリングPW5	O RING, PW5	
57	047502542	1	スプリングピンAW5	PIN, SPRING ROLL AW5	
58	S20554001	1	サドウリヨウメモリイタ	DIFFERENTIAL STITCH CONTROL PLATE	
59	S20548001	2	カラー	COLLAR	
60	018061632	2	アナボルト6X16	BOLT, SOCKET M6X16	
61	S25818051	2	チヨウセツレバーストツバ	STOPPER FOR ADJUST LEVER	
62	060350812	2	バインド35X8	SCREW, BIND M3.5X8	
63	025350332	2	ヒラザガネダイ3.5	WASHER, PLAIN L 3.5	
64	S39694021	1	セットネジツマミ	SET SCREW KNOB	
65	S39695001	1	セットネジ	SET SCREW	
66	S20560001	1	サラバネザガネ	SPRING WASHER	
67	S20561001	1	マイクロチヨウセツネジ	MICRO ADJUST SCREW	
68	S46895001	1	マイクロチヨウセツストツバ	STOPPER, MICRO ADJUST.	
69	S29094001	1	マイクロチヨウセツネジバネ	MICRO ADJUST SPRING	
70	048040342	1	トメワE4	RETAINING RING, E4	
71	S23628051	1	シュオクリバトリツケダイ	FEED DOG SETTING BASE	
72	S23621101	1	ボルト35X8	BOLT, M3.5X8	
73	S23612051	1	セットカラークミ	SET SCREW COLLAR ASSY	
73-1	012060632	2	アナヒラ6X6	SET SCREW, SOCKET (FT) M6X6	
75	※	1	シュオクリバクミ	MAIN FEED DOG ASSY	
75-1	060630712	1	バインド238-56X7	SCREW, BIND SM2.38-56X7	
76	S23621101	1	ボルト35X8	BOLT, M3.5X8	
77	※	1	サドウオクリバ	DIFFERENTIAL FEED DOG	
78	S23621101	1	ボルト35X8	BOLT, M3.5X8	
81	S21091000	1	ヘンシンリンカバークミ	ECCENTRIC WHEEL COVER ASSY	
81-1	S21092000	1	カバースポンジ	COVER SPONGE	
82	S23616101	2	シメネジ4X10	SCREW, M4X10	
83	S20527001	1	アブラキリイタ	OIL REJECTOR PLATE	
84	S23453001	2	ナベコ3X5シール	SCREW 3X5 SEAL	

From the library of: Diamond Needle Corp

F. 上送り関係 / Upper feed mechanism / Obertransportvorrichtung / Mécanisme de l'entraînement supérieur / Mecanismo de la alimentación superior

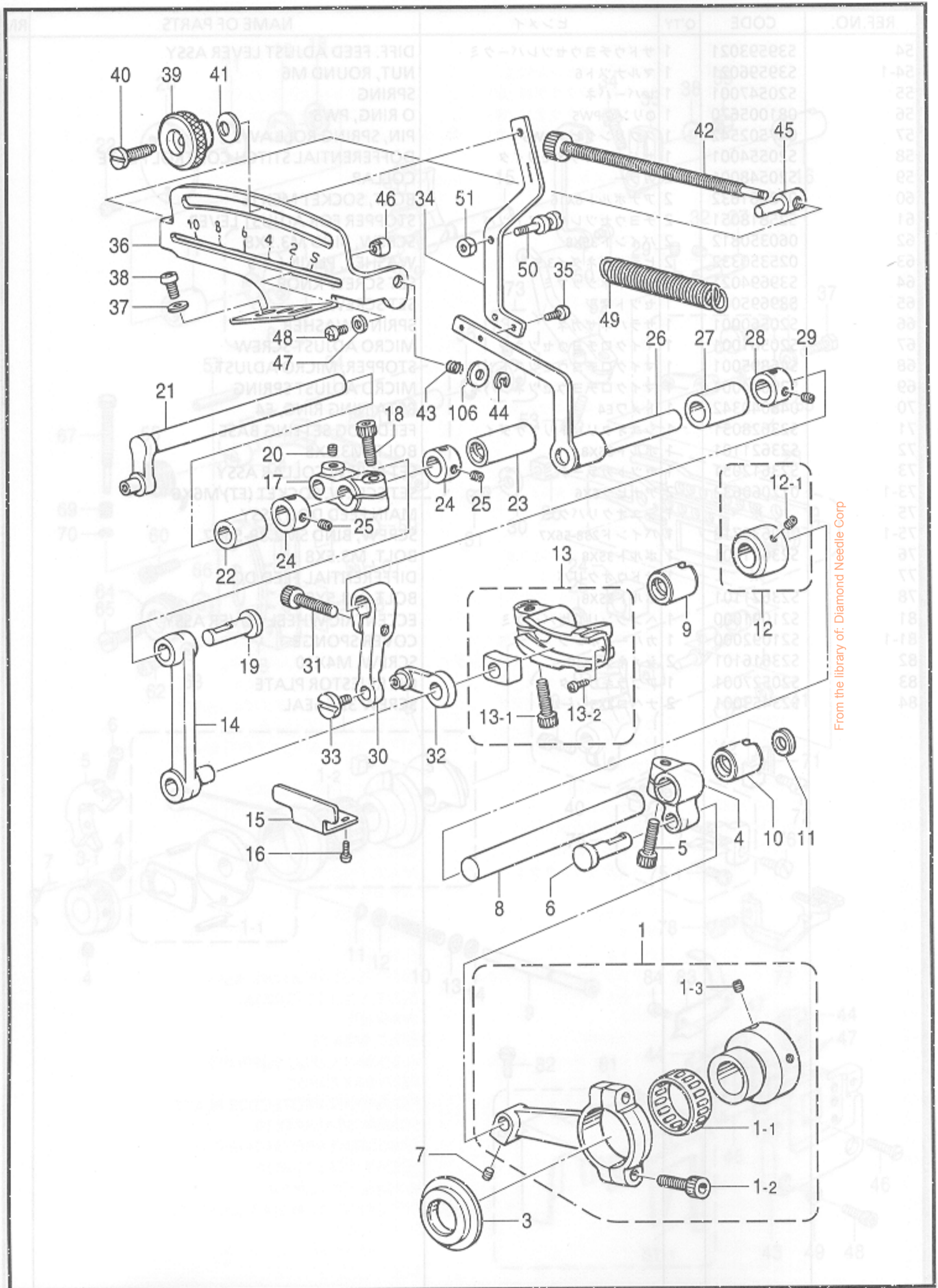

From the library of: Diamond Needle Corp

F. 上送り関係 / Upper feed mechanism / Obertransportvorrichtung / Mécanisme de l'entraînement supérieur / Mecanismo de la alimentación superior

REF.NO.	CODE	Q'TY	ヒンメイ	NAME OF PARTS	RM
1	S20139101	1	スイハイオクリヘンシンリンクミ	ECCENTRIC WHEEL ASSY, W/SCREW	
1-1	S20500001	1	ニードルジクウケ24 (赤)	NEEDLE BEARING, 24 RED	
1-1	S20500002	1	ニードルジクウケ24 (青)	NEEDLE BEARING, 24 BLUE	
1-1	S20500003	1	ニードルジクウケ24 (白)	NEEDLE BEARING, 24 WHITE	
1-2	018401622	2	アナホルト4X16	BOLT, SOCKET M4X16	
1-3	012060632	2	アナヒラ6X6	SET SCREW, SOCKET (FT) M6X6	
3	S20144000	1	オクリロッドササエ	FEED ROD SUPPORT	
4	S20145001	1	オクリウデ	FEED ARM	
5	S20175101	1	アナホルト6X16ホソメ	BOLT, SOCKET M6X16	
6	146532001	1	オクリロッドピン	PIN	
7	012060632	1	アナヒラ6X6	SET SCREW, SOCKET (FT) M6X6	
8	S20146001	1	オクリジク	FEED SHAFT	
9	S39728021	1	メタル11.11-18	BUSH, 11.11-18	
10	S39677021	1	メタル11.11-17	BUSH, 11.11-17	
11	S28044009	1	ゴムセン20.8	RUBBER CAP, 20.8	
12	S23619001	1	セットカラークミ	SET SCREW COLLAR ASSY	
12-1	012060632	2	アナヒラ6X6	SET SCREW, SOCKET (FT) M6X6	
13	S20147001	1	スイハイチヨウセツウテコマクミ	L-FEED ADJUST. ARM BLOCK ASSY	
13-1	S20175101	1	アナホルト6X16ホソメ	BOLT, SOCKET M6X16	
13-2	S20158101	2	ナベコ25X3	SCREW, PAN M2.5X3	
14	S20152001	1	スイハイオクリリンク	FEED ROCK LINK	
15	S20151001	1	スイハイオクリリンクオサエ	FEED ROCK LINK SUPPORT	
16	062300512	2	ナベコ3X5	SCREW, PAN M3X5	
17	S20153001	1	オクリウデ	FEED ARM	
18	S20175101	1	アナホルト6X16ホソメ	BOLT, SOCKET M6X16	
19	146532001	1	オクリロッドピン	PIN	
20	012060632	1	アナヒラ6X6	SET SCREW, SOCKET (FT) M6X6	
21	S20154001	1	スイハイクランクジク	LEVEL FEED CRANK SHAFT	
22	S47031000	1	クランクジクメタルL	CRANKSHAFT BUSHING, L	
23	S20156000	1	クランクジクメタルR	CRANKSHAFT BUSH, R	
24	S20197001	2	セットカラー	SET SCREW COLLAR	
25	012400432	4	アナヒラ4X4	SET SCREW, SOCKET (FT) M4X4	
26	S20157001	1	スイハイチヨウセツレバジク	L-FEED ADJUSTING LEVER SHAFT	
27	S20546001	1	チヨウセツレバーメタル	BUSHING, FEED ADJUSTING LEVER	
28	S20197001	1	セットカラー	SET SCREW COLLAR	
29	012400432	2	アナヒラ4X4	SET SCREW, SOCKET (FT) M4X4	
30	S20159001	1	スイハイチヨウセツレバー	LEVEL FEED ADJUSTING LEVER	
31	018061632	1	アナホルト6X16	BOLT, SOCKET M6X16	
32	S20160001	1	オクリチヨウセツリンク	FEED ADJUSTING LINK	
33	S20189001	1	シメネジ3.5	SCREW, M3.5	
34	S20161101	1	オクリチヨウセツイタ	FEED ADJUSTING PLATE	
35	062350612	2	ナベコM3.5X6	SCREW, PAN M3.5X6	
36	S20162001	1	スイハイメモリイタ	L-FEED LENGTH CONTROL PLATE	
37	025060236	2	ヒラザガネチユウ6	WASHER, PLAIN M 6	
38	062061012	2	ナベコ6X10	SCREW, PAN M6X10	
39	S39694021	1	セットネジツマミ	KNOB, SCREW	
40	S39695001	1	セットネジ	SET SCREW	
41	S20560001	1	サラバネザガネ	WASHER, FLAT SPRING	
42	S20163001	1	マイクロチヨウセツネジ	MICRO ADJUSTING SCREW	
43	S29132001	1	マイクロチヨウセツバネ	SPRING, MICRO ADJUSTING	
44	048040342	1	トメワE4	RETAINING RING, E4	
45	S20165001	1	マイクロチヨウセツストツバ	MICRO ADJUST STOPPER	
46	S25818051	1	チヨウセツレバーストツバ	STOPPER, ADJUSTING LEVER	
47	105161004	1	ザガネ	WASHER	
48	062350612	1	ナベコM3.5X6	SCREW, PAN M3.5X6	
49	151951001	1	クドーレバーヒキバネ	SPRING	
50	S20184101	1	バネカケ	SPRING HOOK	
51	021350106	1	1シユナツト35	NUT, 1 M3.5	
106	025710132	1	ヒラザガネシヨウ4.76	WASHER, PLAIN S 4.76	

From the library of: Diamond Needle Corp

F. 上送り関係 / Upper feed mechanism / Obertransportvorrichtung / Mécanisme de l'entraînement supérieur / Mecanismo de la alimentación superior

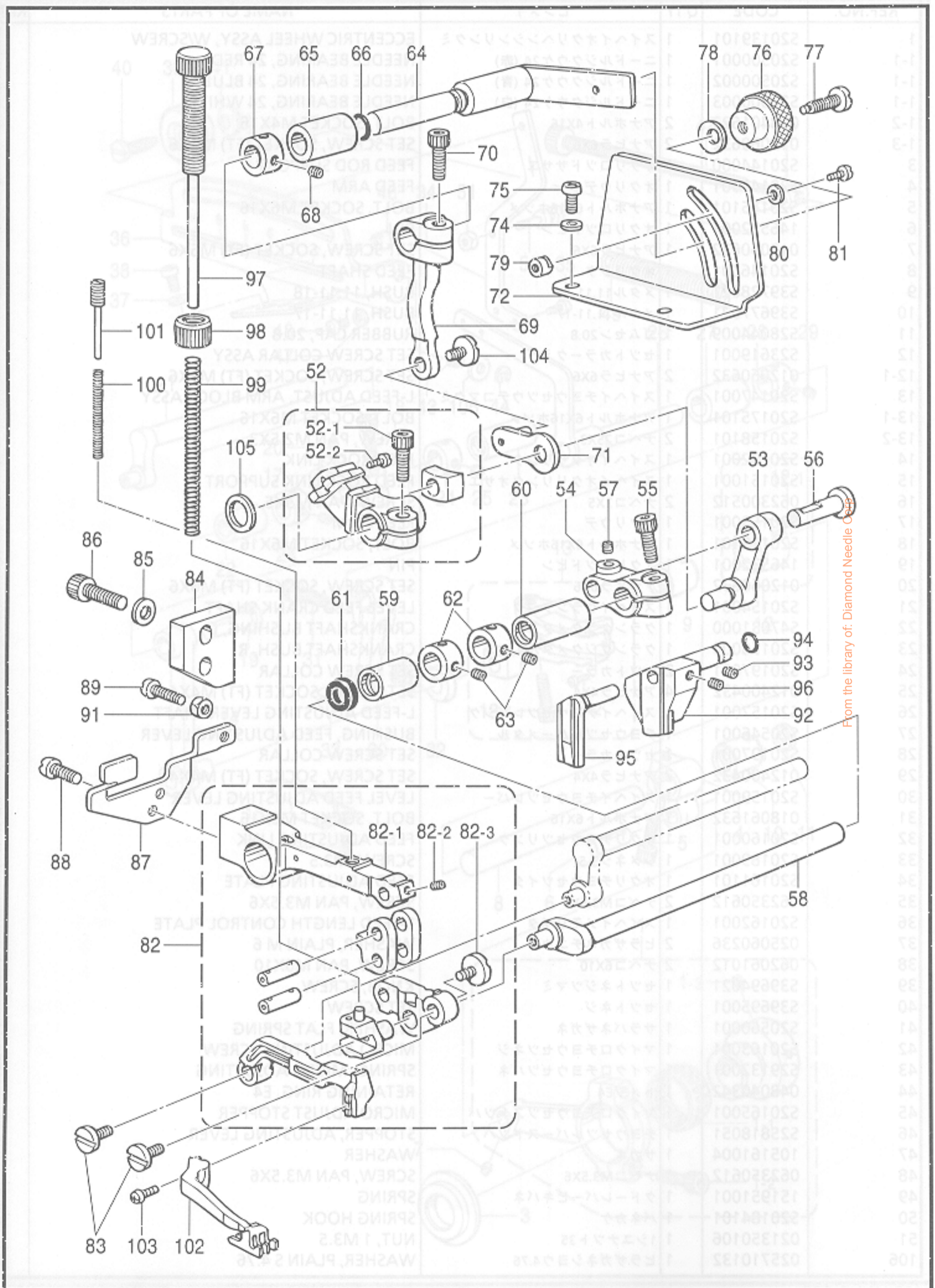

F. 上送り関係 / Upper feed mechanism / Obertransportvorrichtung / Mécanisme de l'entraînement supérieur / Mecanismo de la alimentación superior

スズキ
Suzuki

REF.NO.	CODE	Q'TY	ヒンメイ	NAME OF PARTS	RM
52	S20168001	1	チヨウセツウデコマクミ	V-FEED ADJUST. ARM BLOCK ASSY	
52-1	S20175101	1	アナホルト6X16ホソメ	BOLT, SOCKET M6X16	
52-2	S20158101	2	ナベコ25X3	SCREW, PAN M2.5X3	
53	S20172001	1	ジヨウゲオクリリンク	FEED LIFTING LINK	
54	S20153001	1	オクリウデ	FEED ARM	
55	S20175101	1	アナホルト6X16ホソメ	BOLT, SOCKET M6X16	
56	146532001	1	オクリロッドピン	PIN	
57	012060632	1	アナヒラ6X6	SET SCREW, SOCKET (FT) M6X6	
58	S20174001	1	ジヨウゲクランクジク	FEED LIFTING CRANK SHAFT	
59	S20155000	1	クランクジクメタルL	CRANKSHAFT BUSH, L	
60	S20156000	1	クランクジクメタルR	CRANKSHAFT BUSH, R	
61	155539000	1	ダストシール	DUST SEAL	
62	S20197001	2	セツトカラー	SET SCREW COLLAR	
63	012400432	4	アナヒラ4X4	SET SCREW, SOCKET (FT) M4X4	
64	S20176001	1	ULチヨウセツレバーク	ADJUSTING LEVER SHAFT, UL	
65	S20546001	1	チヨウセツレバーメタル	BUSHING, FEED ADJUSTING LEVER	
66	081005670	1	OリングPW5	O RING, PW5	
67	S20197001	1	セツトカラー	SET SCREW COLLAR	
68	012400432	2	アナヒラ4X4	SET SCREW, SOCKET (FT) M4X4	
69	S20177001	1	ジヨウゲチヨウセツレバー	VERTICAL FEED ADJUSTING LEVER	
70	018061632	1	アナホルト6X16	BOLT, SOCKET M6X16	
71	S20160001	1	オクリチヨウセツリンク	FEED ADJUSTING LINK	
72	S20179001	1	ジヨウゲメモリイタ	V-FEED LENGTH CONTROL PLATE	
74	102707002	2	ザガネ	WASHER, PLAIN 4	
75	060400812	2	バインドM4X8	SCREW, BIND M4X8	
76	S39694021	1	セツトネジツマミ	KNOB, SCREW	
77	S39695001	1	セツトネジ	SET SCREW	
78	S20560001	1	サラバネザガネ	WASHER, FLAT SPRING	
79	S25818051	2	チヨウセツレバーストツバ	STOPPER, ADJUSTING LEVER	
80	105161004	2	ザガネ	WASHER	
81	062350612	2	ナベコM3.5X6	SCREW, PAN M3.5X6	
82	S20181001	1	ウワオクリダイクミ	UPPER FEED BRACKET ASSY	
82-1	S20182001	1	ウワオクリササエダイ	UPPER FEED SUPPORT BAR	
82-2	012400432	2	アナヒラ4X4	SET SCREW, SOCKET (FT) M4X4	
82-3	S20191001	1	シメネジ4	SCREW, M4	
83	S20189001	2	シメネジ3.5	SCREW, M3.5	
84	S20183001	1	ウワオクリクツシヨンドダイ	UPPER FEED CUSHION BRACKET	
85	025060236	2	ヒラザガネチユウ6	WASHER, PLAIN M 6	
86	018061632	2	アナホルト6X16	BOLT, SOCKET M6X16	
87	S46844001	1	ウワオクリアゲ	UPPER FEED LIFTER	
88	062501212	2	ナベコ5X12	SCREW, PAN M5X12	
89	060401412	1	バインドM4X14	SCREW, BIND M4X14	
91	021400202	1	2シユナツト4	NUT, 2 M4	
92	S20193001	1	ウワオクリダイアンナイR	UPPER FEED BAR GUIDE, R	
93	012060632	1	アナヒラ6X6	SET SCREW, SOCKET (FT) M6X6	
94	081005070	1	OリングP5	O RING, P5	
95	S20194001	1	ウワオクリダイアンナイL	UPPER FEED BAR GUIDE, L	
96	012400632	1	アナヒラ4X6	SET SCREW, SOCKET (FT) M4X6	
97	S20195001	1	オサエチヨウセツネジ	ADJUSTING SCREW	
98	S23341009	1	チヨウセツネジツマミナツト	NUT	
99	S00204001	1	ウエオクリオサエバネ	SPRING	
100	S20202001	1	ウワオクリササエダイバネ	SPRING	
101	S20201001	1	ササエダイバネアンナイ	SPRING GUIDE	
102	※	1	ウワオクリバ	UPPER FEED DOG	
103	S23621101	1	ボルト35X8 V92A < 92,93 >	BOLT, M3.5X8	
103	S25525101	1	シメネジ3.5X22	SCREW, M3.5X22	
104	S20189001	1	シメネジ3.5	SCREW, M3.5	
105	S20621001	1	カラー	COLLAR	

From the library of: Diamond Needle Corp

G. 上メス・下メス関係 / Knife mechanism / Messer / Mécanisme du couteau / Mecanismo de la cuchilla

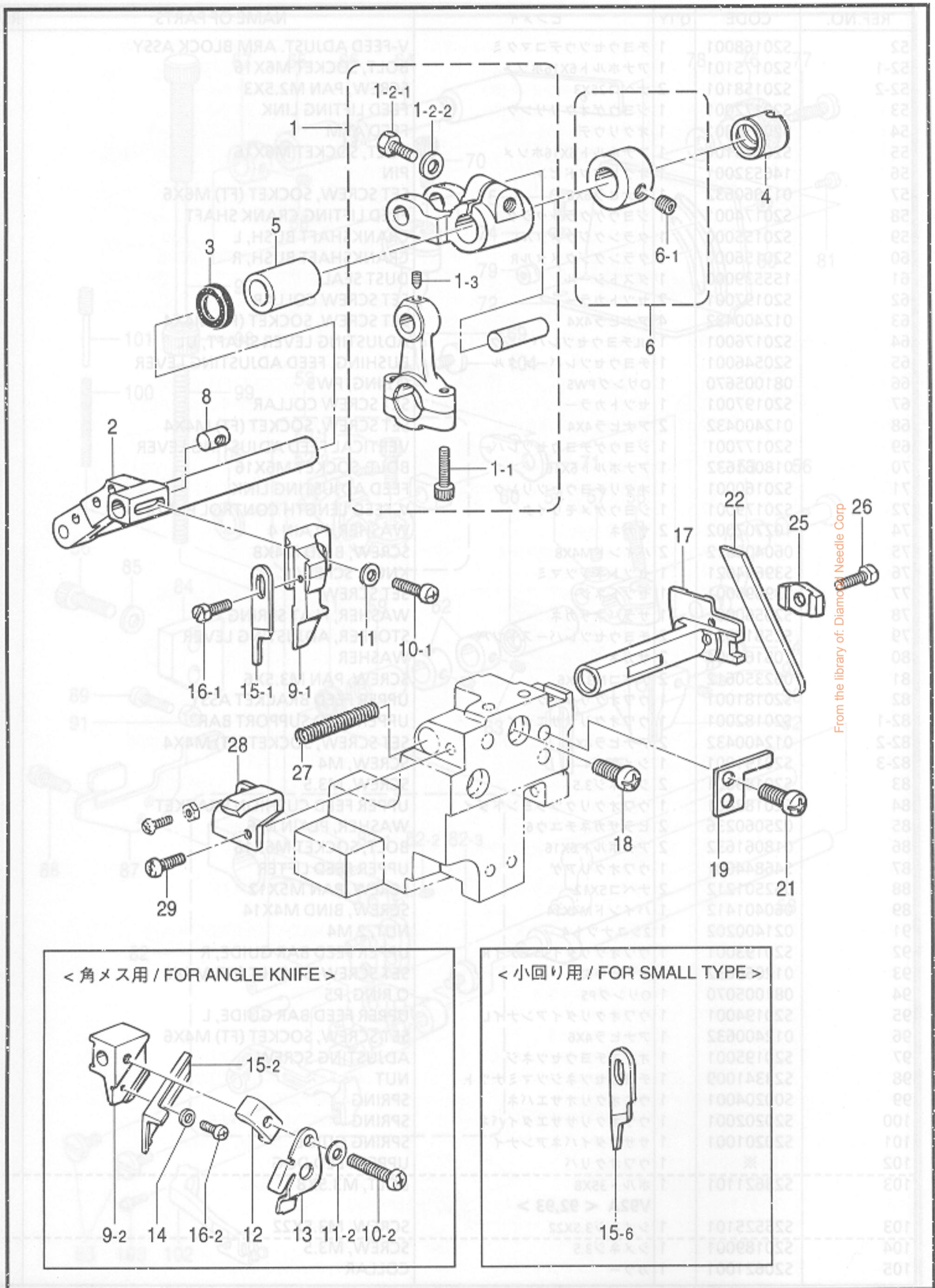

G. 上メス・下メス関係 / Knife mechanism / Messer / Mécanisme du couteau / Mecanismo de la cuchilla

REF.NO.	CODE	Q'TY	ヒンメイ	NAME OF PARTS	RM
1	S46936001	1	ウワメスクランクロッドクミ	UPPER KNIFE CRANK ROD ASSY, I	
1-1	018401622	2	アナボルト4X16	BOLT, SOCKET M4X16	
1-2-1	017061612	1	ボルト6X16	BOLT, M6X16	
1-2-2	118735002	1	ザガネ	WASHER	
1-3	S23342001	1	アタトガリ4X5	SET SCREW, SOCKET (CN) M4X5	
2	S20571101	1	ウワメスサドウウデ	UPPER KNIFE DIFFERENTIAL ARM	
3	155247000	1	ダストシール	DUST SEAL	
4	S39704021	1	ウワメスメタルL	UPPER KNIFE BUSH L	
5	S39677021	1	メタル11.11-17	BUSH, 11.11-17	
6	S23619001	1	セットカラークミ	SET SCREW COLLAR ASSY	
6-1	012060632	2	アナヒラ6X6	SET SCREW, SOCKET (FT) M6X6	
8	S20574001	1	ウワメスダキナツト	NUT	
17	S20591101	1	シタメストリツケダイ	LOWER KNIFE HOLDER	
18	062060812	1	ナベコ6X8	SCREW, PAN M6X8	
19	S39707001	1	シタメストリツケダイアンナイ	LOWER KNIFE HOLDER GUIDE	
21	062060812	2	ナベコ5X8	SCREW, PAN M6X8	
22	S20582001	1	シタメス <T1.5>	LOWER KNIFE <T1.5>	
25	S39708001	1	シタメスオサエ	LOWER KNIFE PRESSER	
26	017500812	1	ボルト5X8	BOLT, M5X8	
27	S20585001	1	シタメストリツケダイバネ	SPRING	
28	S39709021	1	シタメスバネウケ	SPRING HOLDER	
29	060400812	1	バインドM4X8	SCREW, BIND M4X8	
<平メス用部品>				<FOR PLAIN KNIFE>	
9-1	S20589101	1	ウワメスダキ	UPPER KNIFE HOLDER	
10-1	062401212	1	ナベコ4X12	SCREW, PAN M4X12	
11	025040132	1	ヒラザガネシヨウ4	WASHER, PLAIN S 4	
15-1	144074350	1	ウワメス	UPPER KNIFE	
16-1	S23621101	1	ボルト35X8	BOLT, M3.5X8	
<小回り用>				<FOR SMALL TYPE>	
15-6	S30890000	1	ウワメス	UPPER KNIFE	
<角メス用部品>				<FOR ANGLE KNIFE>	
9-2	S20590101	1	ウワメスダキ	UPPER KNIFE HOLDER	
10-2	062402512	1	ナベコM4X25	SCREW, PAN M4X25	
11-2	125324001	1	ヒラザガネダイ4アツ	WASHER, PLAIN L 4	
12	S20577001	1	ウワメスオサエ	UPPER KNIFE PRESSER	
13	S20578101	1	ウワメスオサエイタ	UPPER KNIFE PRESSER PLATE	
14	025030132	1	ヒラザガネシヨウ3	WASHER, PLAIN S 3	
15-2	S20897101	1	カクメス幅狭 波刃	ANGLE KNIFE, NARROW WAVE EDGE	
16-2	062300412	1	ナベコ3X4	SCREW, PAN M3X4	
<オプションパーツ>				<OPTION PARTS>	
15-2	S20896101	1	カクメス 幅狭	ANGLE KNIFE, NARROW	
15-2	S20579101	1	カクメス 幅広	ANGLE KNIFE, WIDE	
15-2	S20898101	1	カクメス 幅広 波刃	ANGLE KNIFE, WIDE WAVE EDGE	

From the library of: Diamond Needle Corp

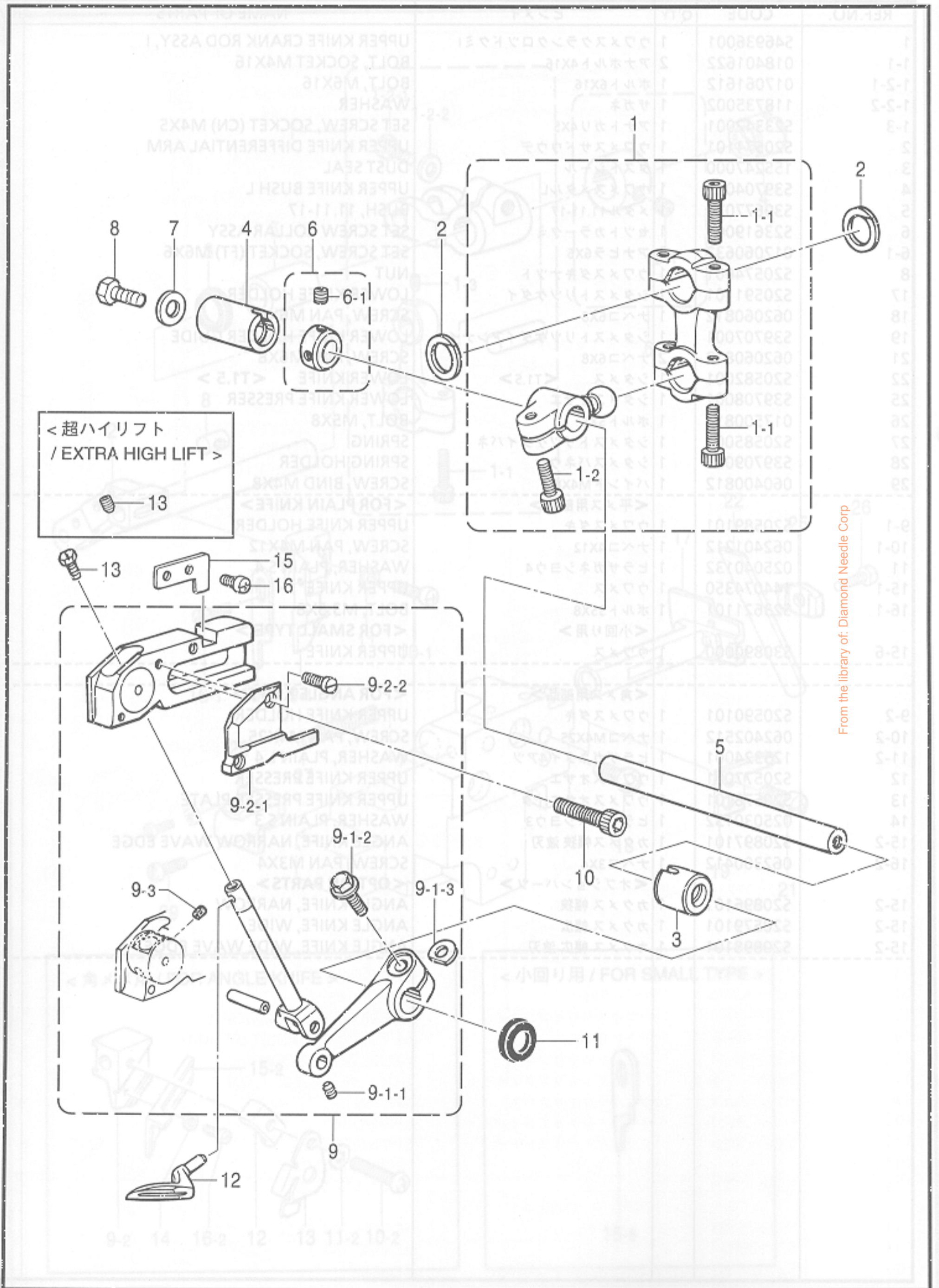

From the library of: Diamond Needle Corp

H. 上ルーパ関係 / Over looper mechanism / Oberen Greifer / Mécanisme du boucleur supérieur / Mecanismo del presilladora superior

REF.NO.	CODE	Q'TY	ヒンメイ	NAME OF PARTS	RM
1	S46940001	1	ウワルーパロッドクミ HE	OVER LOOPER ROD ASSY, HE	
1-1	018401622	4	アナボルト 4X16	BOLT, SOCKET M4X16	
1-2	S23346101	1	アナボルト 6X14 ホソメ	BOLT, SOCKET M6X14	
2	S20598000	2	ロッドフレドメ	ROD STOPPER	
3	S39728021	1	メタル 11.11-18	BUSH, 11.11-18	
4	S39677021	1	メタル 11.11-17	BUSH, 11.11-17	
5	S20601001	1	ウワルーパジク	OVER LOOPER SHAFT	
6	S23619001	1	セットカラークミ	SET SCREW COLLAR ASSY	
6-1	012060632	2	アナヒラ 6X6	SET SCREW, SOCKET (FT) M6X6	
7	S23626001	1	ザガネ	WASHER	
8	017060812	1	ボルト 6X8	BOLT, M6X8	
< ハイリフト用 >				< FOR HIGH LIFT >	
9	S46896001	1	ウワルーパキコウクミ SH	OVER LOOPER MECHANISM ASSY, SH	
13	S46903001	1	アタマツキトメネジ 4X5	SET SCREW, M4X5	
< 超ハイリフト用 >				< FOR EXTRA HIGH LIFT >	
9-1	S46901001	1	ウワルーパキコウクミ E	OVER LOOPER MECHANISM ASSY, E	
13	012400432	1	アナヒラ 4X4	SET SCREW, SOCKET (FT) M4X4	
9-1-1	S23342001	1	アネトガリ 4X5	SET SCREW, SOCKET (CN) M4X5	
9-1-2	S46899001	1	ザガネツキボルト 6X16	BOLT, (S/P WASHER) M6X16	
9-1-3	155162001	1	スペーサ	SPACER	
9-2-1	S38320100	1	ウワルーパアンナイオサエ	OVER LOOPER GUIDE HOLDER	
9-2-2	S20355002	2	シメネジ 3X8.5	SCREW, M3X8.5	
9-3	S29700000	2	ウワルーパアンナイフエルト	OVER LOOPER GUIDE FELT	
10	018061432	2	アナボルト 6X14	BOLT, SOCKET M6X14	
11	155247000	1	ダストシール	DUST SEAL	
12	※	1	ウワルーパ	OVER LOOPER	
15	S23611101	1	アンナイメタルイチギメイタ	POTISIONING PLATE, GUIDE BUSH	
16	060400612	2	バインド M4X6	SCREW, BIND M4X6	

From the library of: Diamond Needle Corp



J. 下ルーパー関係 / Under looper mechanism / Unterer Greifer / Mécanisme du boucleur inférieur / Mecanismo del presilladora inferior

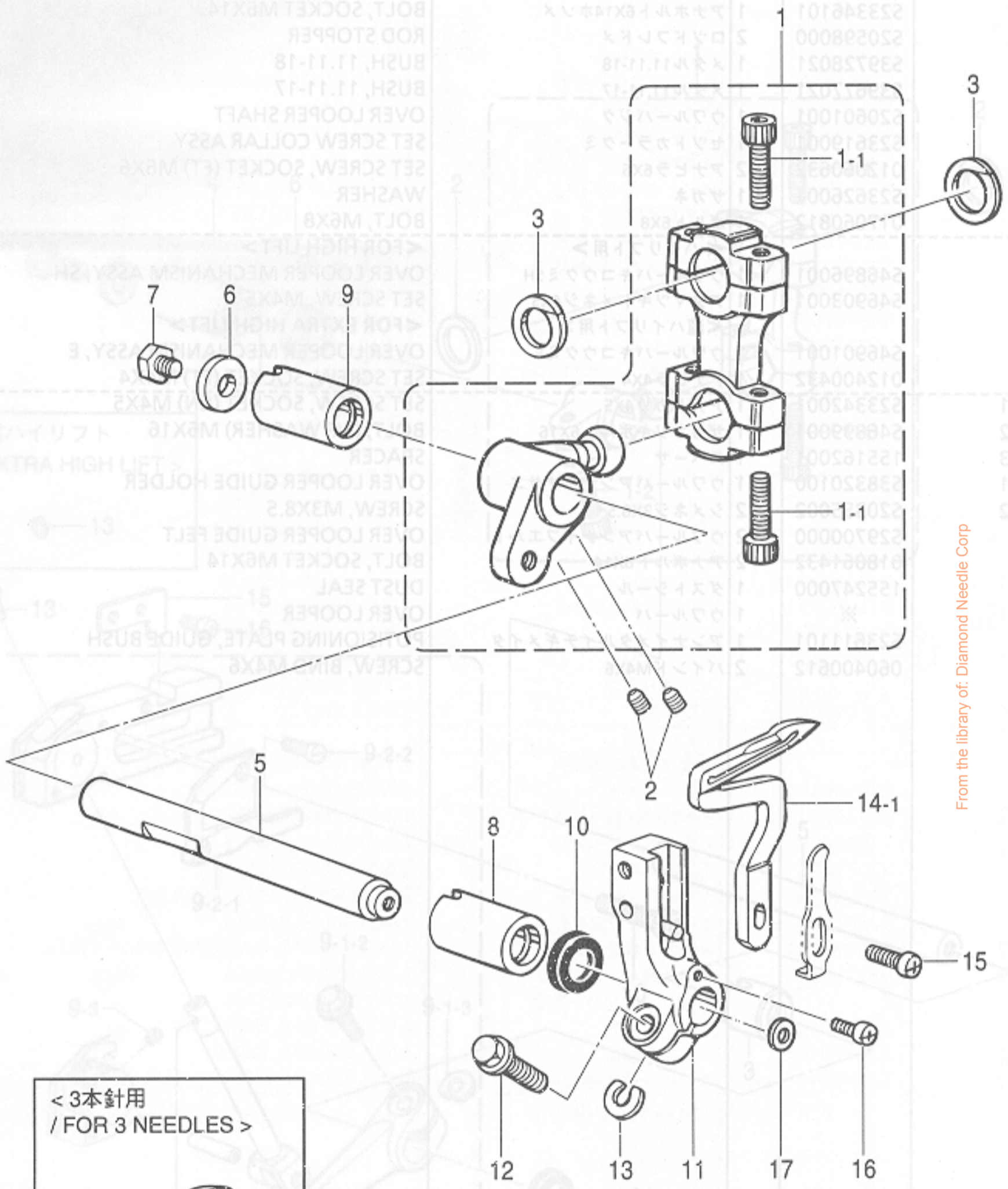

< 3本針用
/ FOR 3 NEEDLES >

14-2

From the library of: Diamond Needle Corp

J. 下ルーパ関係 / Under looper mechanism / Unterer Greifer / Mécanisme du boucleur inférieur / Mecanismo del presilladora inferior

REF.NO.	CODE	Q'TY	ヒンメイ	NAME OF PARTS	RM
1	S46943001	1	<ハイリフト用> シタルーパロッドクミSH	<FOR HIGH LIFT> UNDER LOOPER ROD ASSY, I-SH	
1	S46944001	1	<超ハイリフト用> シタルーパロッドクミE	<FOR EXTRA HIGH LIFT> UNDER LOOPER ROD ASSY, I-E	
1-1	018401622	4	アナボルト4X16	BOLT, SOCKET M4X16	
2	012060632	2	アナヒラ6X6	SET SCREW, SOCKET (FT) M6X6	
3	S20598000	2	ロッドフレドメ	ROD STOPPER	
5	S46904001	1	シタルーパジク	UNDER LOOPER SHAFT	
6	S23626001	1	ザガネ	WASHER	
7	017060812	1	ボルト6X8	BOLT, M6X8	
8	S39728021	1	メタル11.11-18	BUSH, 11.11-18	
9	S39677021	1	メタル11.11-17	BUSH, 11.11-17	
10	155247000	1	ダストシール	DUST SEAL	
11	S20625151	1	シタルーパトリツケダイ	UNDER LOOPER HOLDER	
12	S23614101	1	フランジボルト5X14	BOLT, M5X14	
13	148782001	1	スペーサ	SPACER	
14-1	S20626001	1	シタルーパ	UNDER LOOPER	
15	060351012	1	バインド3.5X10	SCREW, BIND M3.5X10	
16	060350812	1	バインド3.5X8	SCREW, BIND M3.5X8	
17	158722002	1	ザガネ4.2	WASHER, PLAIN 4.2	
14-2	S20627001	1	<3本針用> シタルーパ	<FOR "3 NEEDLES"> UNDER LOOPER	
20	S20649051	1	縦ゴジク	LONGITUDINAL FEED SHAFT	
21	S39728021	1	縦ゴジクメタル	LONGITUDINAL FEED SHAFT BUSH, F	
22	S39742021	1	縦ゴジクメタル	LONGITUDINAL FEED SHAFT BUSH, B	
23	155261020	1	ダストシール	DUST SEAL	
24	S20652001	1	縦ゴジクメタル	D-CHAIN STITCH UNDER LOOPER HOLDER	
25	S23614101	1	フランジボルト5X14	BOLT, M5X14	
26	148782001	1	スペーサ	SPACER	
27	S20653001	1	縦ゴジク	D-CHAIN STITCH LOOPER	
28	060350812	1	バインド3.5X8	SCREW, BIND M3.5X8	
29	S20654001	1	シタルーパチヨウセンザガネ	WASHER	
30	S23456101	1	ナベコ2.5X6	SCREW, PAN M2.5X6	

From the library of: Diamond Needle Corp

K. 二重環ルーパ関係 / Double chain stitch looper mechanism / Doppelkettenstichgreifer
 / Mécanisme du boucleur pour point de chaînette double / Mecanismo del presilladora de
 double cadeneta

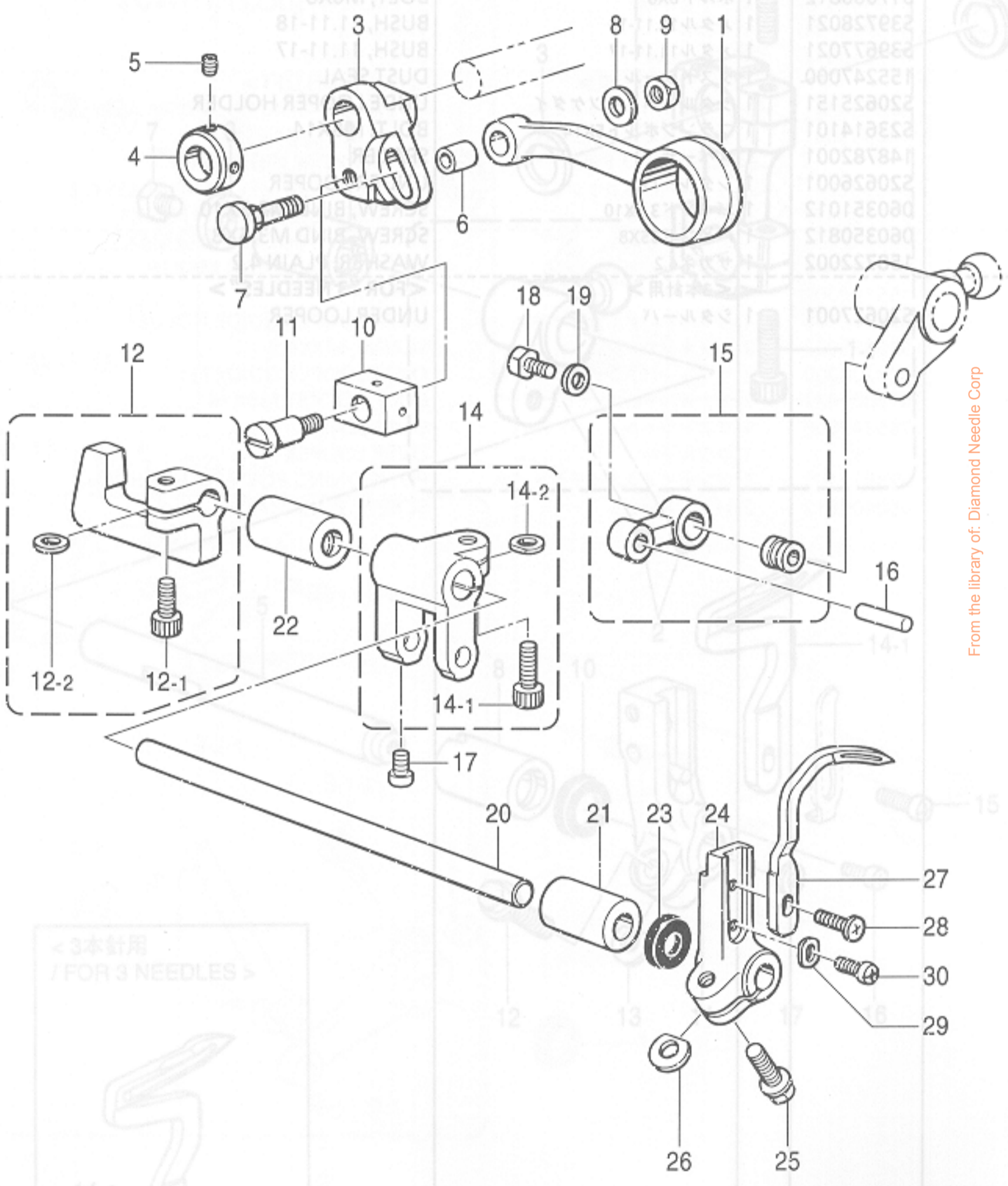

From the library of: Diamond Needle Corp

< 3本針用
 / FOR 3 NEEDLES >

K. 二重環ルーパ関係 / Double chain stitch looper mechanism / Doppelkettenstichgreifer /
 Mécanisme du boucieur pour point de chaînette double /
 Mecanismo del presilladora de double cadeneta

REF.NO.	CODE	Q'TY	ヒンメイ	NAME OF PARTS	RM
1	S39729021	1	ゼンゴロツドクミ	LONGITUDINAL FEED ROD ASSY	
3	S39732021	1	ゼンゴウデ	LONGITUDINAL FEED ARM	
4	S39733001	1	セットカラー	SET SCREW COLLAR	
5	012400432	2	アナヒラ4X4	SET SCREW, SOCKET (FT) M4X4	
6	S29102001	1	ゼンゴロツドブツシユ	LONGITUDINAL FEED ROD BUSH	
7	S39734021	1	ゼンゴウデネジ	LONGITUDINAL FEED SCREW	
8	S39690021	1	ザガネ	WASHER	
9	021500216	1	2シユナツト5	NUT, 2 M5	
10	S20640001	1	ゼンゴウデカクゴマ	LONGITUDINAL FEED ARM SLIDE BLOCK	
11	S20641001	1	ダンネジ5	SHOULDER SCREW 5	
12	S31881101	1	カクゴマダキネジツキ	SLIDE BLOCK HOLDER	
12-1	018061432	1	アナボルト6X14	BOLT, SOCKET M6X14	
12-2	155162001	1	スヘーサ	SPACER	
14	S44935001	1	ニジユウカンウデクミ	D-CHAIN STITCH LOOPER LEVER ASSY	
14-1	018061432	1	アナボルト6X14	BOLT, SOCKET M6X14	
14-2	155162001	1	スヘーサ	SPACER	
15	S44937001	1	ニジユウカンリンククミ	D-CHAIN STITCH LOOPER LINK ASSY	
16	S44939001	1	ニジユウカンウデジク	D-CHAIN STITCH LOOPER LEVER PIN	
17	062300612	1	ナベコ3X6	SCREW, PAN M3X6	
18	S23360001	1	ボルト5X15	BOLT, M5X15	
19	S39690021	1	ザガネ	WASHER	
20	S20649051	1	ゼンゴジク	LONGITUDINAL FEED SHAFT	
21	S39741021	1	ゼンゴジクメタルF	LONGITUDINAL FEED SHAFT BUSH, F	
22	S39742021	1	ゼンゴジクメタルB	LONGITUDINAL FEED SHAFT BUSH, B	
23	155261000	1	ダストシール	DUST SEAL	
24	S20652001	1	ニジユウカンルーパホルダ	D-CHAIN STITCH LOOPER HOLDER	
25	S23614101	1	フランジボルト5X14	BOLT, M5X14	
26	148782001	1	スヘーサ	SPACER	
27	S20653001	1	ニジユウカンルーパ	D-CHAIN STITCH LOOPER	
28	060350812	1	バインド35X8	SCREW, BIND M3.5X8	
29	S20654001	1	ルーパチヨウセツザガネ	WASHER	
30	S23456101	1	ナベコ25X6	SCREW, PAN M2.5X6	
36	060350812	1	バインドM4X8	SCREW, BIND M4X8	
38	S49337000	1	クミヒモ70	WICK, L=70	
39	S20180001	2	オイルパイプ	OIL FEEDING PIPE	
40	S20200001	1	オイルチューブ	OIL TUBE, L=370	
42	S25879001	1	チューブササエ	TUBE SUPPORT	
43	060400812	1	バインドM4X8	SCREW, BIND M4X8	
44	S20392000	1	フェルト	FELT	
45	S25526000	1	ピン	PIN	
46	S43523000	1	フィルター	FILTER ASSY	
46-1	S43522000	1	オイルフィルター	OIL FILTER	
46-2	S43521000	1	ロカモウ	FILTER, D	

From the library of: Diamond Needle Corp.

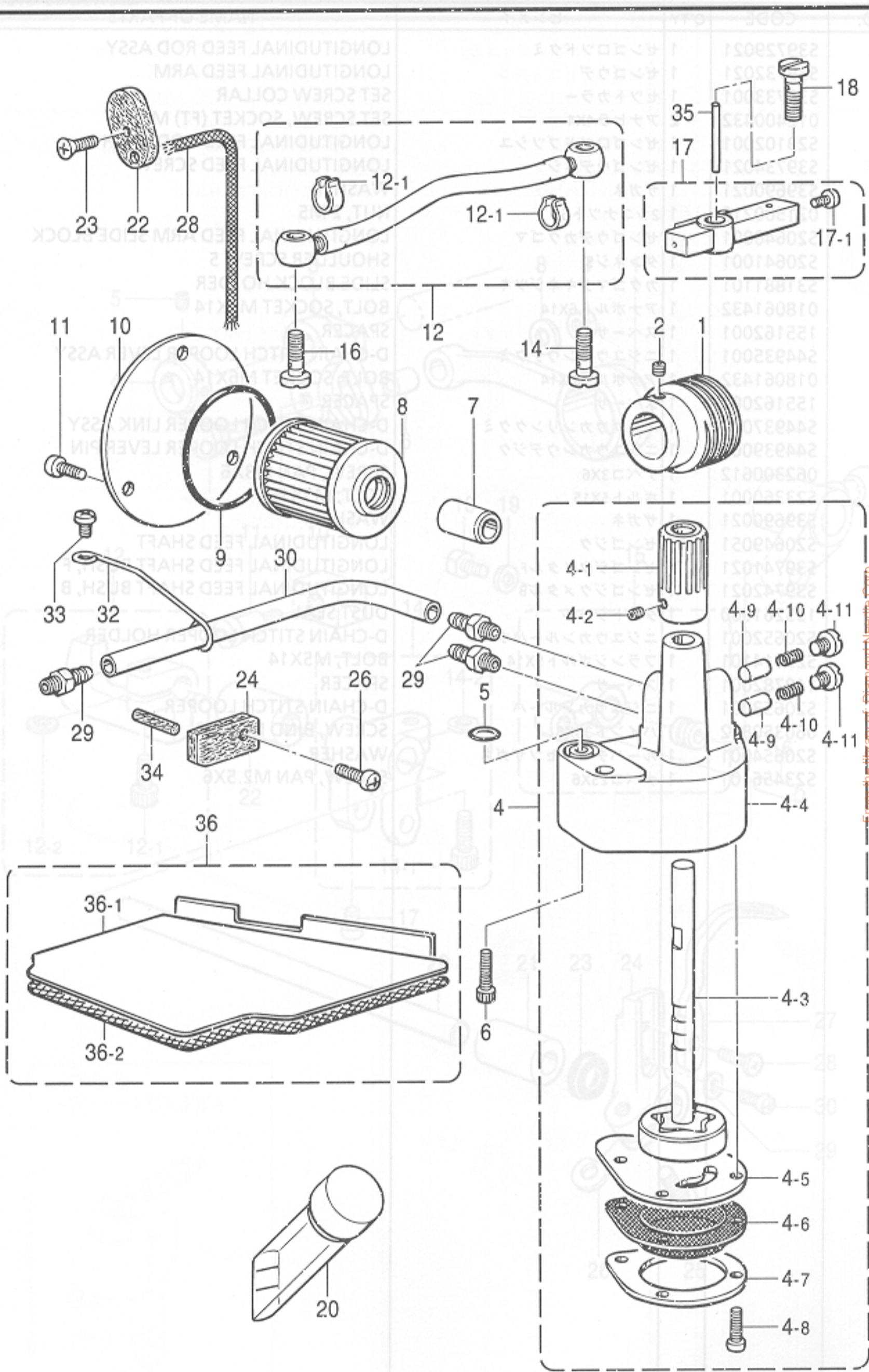

From the library of: Diamond Needle Corp

REF.NO.	CODE	Q'TY	ヒンメイ	NAME OF PARTS	RM
1	S20655101	1	ウオーム	WORM	
2	012500532	2	アナヒラ5X5	SET SCREW, SOCKET (FT) M5X5	
4	S20300101	1	ドロコイドポンプクミ	PUMP ASSY	
4-1	S20657001	1	ウオームホイール	WORM WHEEL	
4-2	012400536	2	アナヒラ4X5	SET SCREW, SOCKET (FT) M4X5	
4-3	S20301001	1	ポンプロータークミ	PUMP INNER ROTER ASSY	
4-4	S20303000	1	ポンプケース	PUMP CASE	
4-5	S20661001	1	ポンプタイフタ	PUMP BODY COVER	
4-6	S20662100	1	ロカモウ	OIL FILTER	
4-7	S20663000	1	ロカモウオサエ	FILTER SUPPORT	
4-8	062351016	4	ナベコ3.5X10	SCREW, PAN M3.5X10	
4-9	144875001	2	フランジヤ	PLUNGER	
4-10	144876001	2	フランジヤバネ	SPRING	
4-11	S23460001	2	ナベコ6X5	SCREW, PAN M6X5	
5	081008070	1	OリングP8	O RING, P8	
6	018061432	2	アナボルト6X14	BOLT, SOCKET M6X14	
7	S08957001	1	オイルクチ	OIL FEEDING PIPE	
8	S08956100	1	オイルフィルター	OIL FILTER	
9	081044070	1	OリングP44	O RING, P44	
10	S12987002	1	オイルフィルターフタ	CAP, OIL FILTER	
11	060400812	3	バインドM4X8	SCREW, BIND M4X8	
12	S46905001	1	ビニルチューブクミ	OIL TUBE ASSY	
12-1	147942001	2	ビニルチューブトメガネ	STOP RING	
14	S20199001	1	ハイユパイプツギテ	OIL PIPE JOINT	
16	S20199001	1	ハイユパイプツギテ	OIL PIPE JOINT	
17	S20666001	1	キユウユパイプクミ	OIL PIPE ASSY	
17-1	060400512	1	バインドM4X5	SCREW, BIND M4X5	
18	S20199001	1	ハイユパイプツギテ	OIL PIPE JOINT	
20	148084001	1	オイルゲージマド	OIL GAUGE WINDOW	
22	S20668200	1	ハリボウリンクフェルト	NEEDLE BAR LINK FELT	
23	061400812	1	サラコM4X8	SCREW, FLAT M4X8	
24	S20669000	1	フェルト	FELT	
26	060400812	1	バインドM4X8	SCREW, BIND M4X8	
28	S49337000	1	クミヒモ70	WICK, L = 70	
29	S20180001	3	オイルクチ	OIL FEEDING PIPE	
30	S20200001	1	ビニルチューブ	OIL TUBE, L = 370	
32	S25879001	1	チューブササエ	TUBE SUPPORT	
33	060400812	1	バインドM4X8	SCREW, BIND M4X8	
34	S20392000	1	フェルト	FELT	
35	S25526000	1	ピン	PIN	
36	S43523000	1	フィルタークミ	FILTER ASSY	
36-1	S43522000	1	オイルフィルター	OIL FILTER	
36-2	S43521000	1	ロカモウD	FILTER, D	

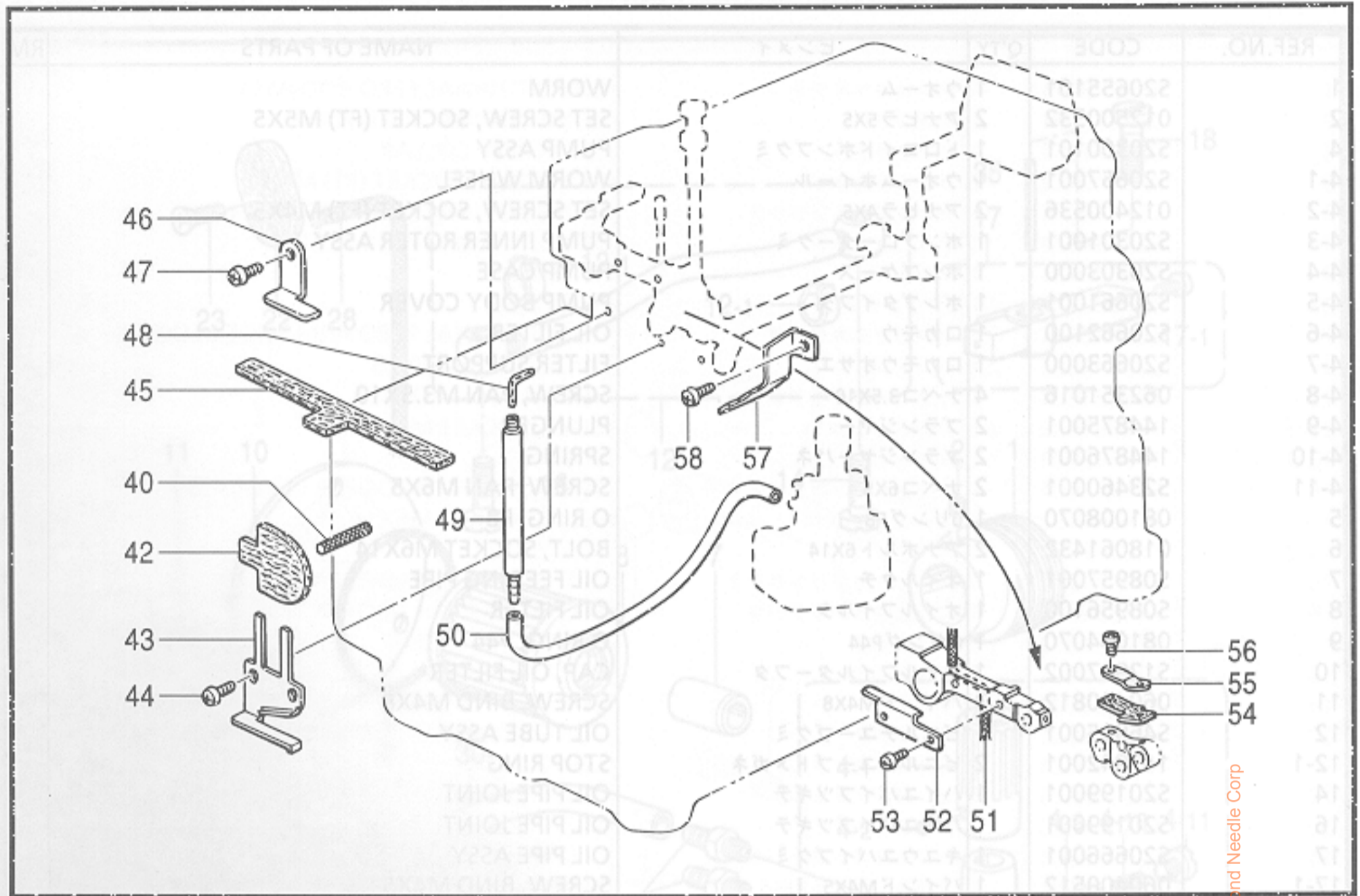

185-V9A,B-350

From the library of: Diamond Needle Corp

L. 給油潤滑関係 / Lubrication / Schmierung / Lubrification / Lubricación

REF.NO.	CODE	Q'TY	ヒンメイ	NAME OF PARTS	RM
40	S20213000	1	クミヒモ	WICK, L = 22	
42	S20214000	1	キユウユフェルト	FELT	
43	S20215001	1	フェルトオサエ	FELT SUPPORT	
44	062400612	2	ナベコM4X6	SCREW, PAN M4X6	
45	S20216000	1	カイシユウフェルト	FELT	
46	S20217001	1	フェルトオサエ	FELT SUPPORT	
47	062400612	1	ナベコM4X6	SCREW, PAN M4X6	
48	147363000	1	フェルト	FELT	
49	S20218001	1	パイプツギテ	PIPE JOINT	
50	S20219001	1	ビニルチューブ	OIL TUBE	
51	S07463000	1	クミヒモ	WICK, L = 70	
52	S20220001	1	オイルヒモアンナイ	WICK GUIDE	
53	S20158101	2	ナベコ25X3	SCREW, PAN M2.5X3	
54	S20221000	1	フェルト	FELT	
55	S20222001	1	フェルトオサエ	FELT SUPPORT	
56	S20158101	2	ナベコ25X3	SCREW, PAN M2.5X3	
57	S20178001	1	ボウジンイタ	FRAGMENT PROTECTOR PLATE	
58	062400612	1	ナベコM4X6	SCREW, PAN M4X6	

185-V9A,B-350

30	060300612	1	バインドM3X4	SCREW, BIND M3X4	
31	S21135001	1	ハテンピン	LOOPER THREAD TAKE-UP	
32	060400612	2	バインドM4X6	SCREW, BIND M4X6	
33	S21137001	1	ハイトアンナイ	LOOPER THREAD GUIDE	
35	S21136101	1	ハイトアンナイ	OVER LOOPER THREAD GUIDE	
36	060400612	1	バインドM4X6	SCREW, BIND M4X6	
37	S20697001	1	シタルーハイ	UNDER LOOPER THREAD GUIDE	
38-1	S21137001	1	ハイトアンナイ	NEEDLE THREAD GUIDE	
39	060400612	1	バインドM4X6	SCREW, BIND M4X6	
40-1	S21137001	1	ハイトアンナイ	NEEDLE THREAD GUIDE	
41	060400612	1	バインドM4X6	SCREW, BIND M4X6	
42	S21130001	1	ハイトアンナイ	NEEDLE THREAD TAKE-UP	
43	060400612	2	バインドM4X6	SCREW, BIND M4X6	
44-1	S21125001	1	ハイトアンナイ	NEEDLE THREAD GUIDE	
45	060400612	1	バインドM4X6	SCREW, BIND M4X6	
46	S38330001	1	ハイトオサエホルダー	NEEDLE THREAD PRESSER HOLDER	
47	146477001	1	アナドメネジ3.18クボミ	SET SCREW, SOCKET (CP)	
48	S206990001	1	ハイトオサエカラー	NEEDLE THREAD PRESSER COLLAR	
49	S20690001	1	ハイトオサエパネ	SPRING	
50	S20691001	1	ハイトオサエホルダー	NEEDLE THREAD PRESSER PLATE	
51	S20743001	1	ハイトアンナイ	NEEDLE THREAD GUIDE	
52	060300612	1	バインドM3X6	SCREW, BIND M3X6	
53	S20694001	1	DLイトアンナイ	LOOPER THREAD GUIDE	
54	060400612	1	バインドM4X6	SCREW, BIND M4X6	
55	S20691001	1	DLイトアンナイ	THREAD GUIDE PIPE	
56	S20697001	1	イトアンナイパイプ	THREAD GUIDE PIPE SUPPORT	
57	060400612	1	バインドM4X6	SCREW, BIND M4X6	
58	S20697001	1	DLイトアンナイ	LOOPER THREAD GUIDE	
59	S20698121	1	イトアンナイシボウ	TENSION STUD	
60	144504001	2	イトアンナイサラ	THREAD GUIDE DISC	
61	158782101	1	イトアンナイ	PRE TENSION SPRING	

From the library of: Diamond Needle Corp

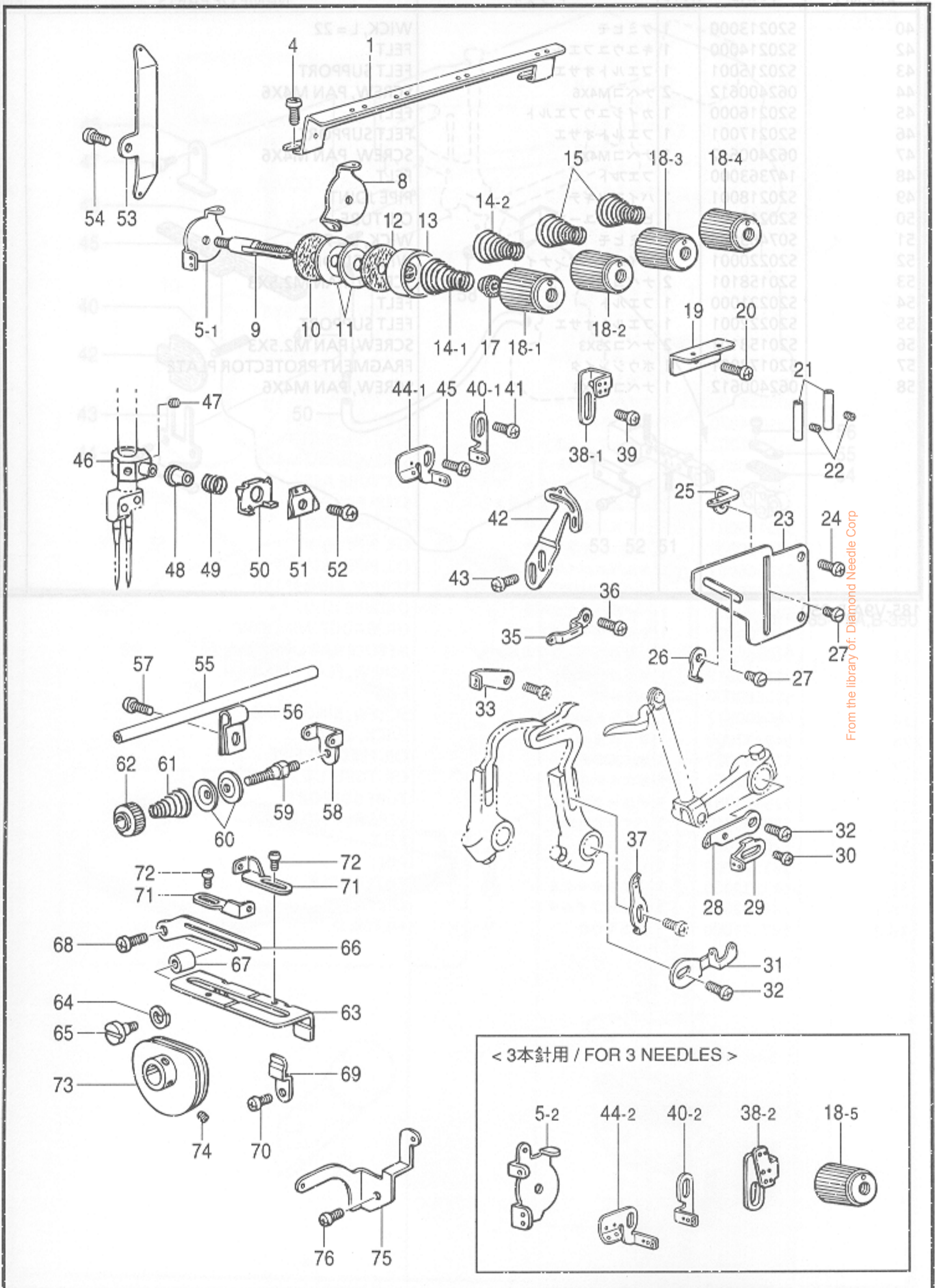

From the library of: Diamond Needle Corp

REF.NO.	CODE	Q'TY	ヒンメイ	NAME OF PARTS	RM
1	S20672001	1	シユイトアンナイ	MAIN THREAD GUIDE	
4	060400812	2	バインドM4X8	SCREW, BIND M4X8	
5-1	S20693001	1	ハリイトアンナイ2N	NEEDLE GUIDE, 2-NEEDLE	
8	S20675001	3	チヨウシサライトアンナイ	TENSION DISC THREAD GUIDE	
9	S20676051	4	イトチヨウシボウ	TENSION STUD	
10	S20677000	4	イトチヨウシサラフェルト	TENSION DISC FELT	
11	S20673001	8	イトチヨウシサラ	TENSION DISC	
12	110832009	4	イトチヨウシサラフェルト	TENSION DISC FELT	
13	144103009	4	イトチヨウシサラオサエ	TENSION DISC PRESSER	
14-1	S20678001	1	イトチヨウシバネL	TENSION SPRING, L	
14-2	S32276001	1	イトチヨウシバネLL	TENSION SPRING, LL	
15	S20679001	2	イトチヨウシバネM	TENSION SPRING, M	
17	S20681000	4	チヨウシバネウエザガネ	WASHER	
18-1	S20682103	1	イトチヨウシナツト(赤)	TENSION NUT, RED	
18-2	S20682101	1	イトチヨウシナツト(水色)	TENSION NUT, LIGHT BLUE	
18-3	S20682104	1	イトチヨウシナツト(黄)	TENSION NUT, YELLOW	
18-4	S20682102	1	イトチヨウシナツト(緑)	TENSION NUT, GREEN	
19	S20683001	1	ルーハイトアンナイ	LOOPER THREAD GUIDE	
20	060400812	1	バインドM4X8	SCREW, BIND M4X8	
21	146592001	2	イトアンナイパイプ	THREAD GUIDE PIPE	
22	S23452002	2	アナヒラ4X3.2	SET SCREW, SOCKET (FT) M4X3.2	
23	S20684101	1	イトアンナイドダイ	THREAD GUIDE BRACKET	
24	060400612	2	バインドM4X6	SCREW, BIND M4X6	
25	S20685001	1	シタルーハイトアンナイR	UNDER LOOPER THREAD GUIDE, R	
26	S20686001	1	ウワルーハイトアンナイR	OVER LOOPER THREAD GUIDE, R	
27	S23418002	2	シメネジ4X5	SCREW, M4X5	
28	S21133001	1	ウワルーハテンビンR	OVER LOOPER THREAD TAKE-UP, R	
29	S21134001	1	シタルーハテンビンR	UNDER LOOPER THREAD TAKE-UP, R	
30	060300412	1	バインドM3X4	SCREW, BIND M3X4	
31	S21135001	1	ルーハテンビンL	LOOPER THREAD TAKE-UP, L	
32	060400612	2	バインドM4X6	SCREW, BIND M4X6	
33	S21137001	1	ルーハイトアンナイM1	LOOPER THREAD GUIDE, M1	
35	S21136101	1	ウワルーハイトアンナイL	OVER LOOPER THREAD GUIDE, L	
36	060400612	1	バインドM4X6	SCREW, BIND M4X6	
37	S20687001	1	シタルーハイトアンナイL	UNDER LOOPER THREAD GUIDE, L	
38-1	S21127001	1	ハリイトアンナイC	NEEDLE THREAD GUIDE, C	
39	060400612	1	バインドM4X6	SCREW, BIND M4X6	
40-1	S21126001	1	ハリイトアンナイB	NEEDLE THREAD GUIDE, B	
41	060400612	1	バインドM4X6	SCREW, BIND M4X6	
42	S21130051	1	ハリイトテンビンA	NEEDLE THREAD TAKE-UP, A	
43	060400812	2	バインドM4X8	SCREW, BIND M4X8	
44-1	S21125001	1	ハリイトアンナイA	NEEDLE THREAD GUIDE, A	
45	060400612	1	バインドM4X6	SCREW, BIND M4X6	
46	S38330050	1	ハリイトオサエホルダー	NEEDLE THREAD PRESSER HOLDER	
47	146427001	2	アナトメネジ3.18クボミ	SET SCREW, SOCKET (CP) SM3.18	
48	S20689001	1	ハリイトオサエカラー	NEEDLE THREAD PRESSER COLLAR	
49	S20690001	1	ハリイトオサエバネ	SPRING	
50	S20691001	1	ハリイトオサエイタ	NEEDLE THREAD PRESSER PLATE	
51	S20743001	1	ハリイトアンナイ	NEEDLE THREAD GUIDE	
52	060300612	1	バインドM3X6	SCREW, BIND M3X6	
53	S20694001	1	DLイトアンナイB	LOOPER THREAD GUIDE	
54	060400612	1	バインドM4X6	SCREW, BIND M4X6	
55	S20695001	1	DLイトアンナイパイプ	THREAD GUIDE PIPE	
56	S20696001	1	イトアンナイパイプササエ	THREAD GUIDE PIPE SUPPORT	
57	060400612	1	バインドM4X6	SCREW, BIND M4X6	
58	S20697001	1	DLチヨウシサライトアンナイ	LOOPER THREAD GUIDE	
59	S20698121	1	イトチヨウシボウ	TENSION STUD	
60	144504001	2	イトアンナイサラ	THREAD GUIDE DISC	
61	158782101	1	プレテンションバネ	PRE TENSION SPRING	

From the library of: Diamond Needle Corp

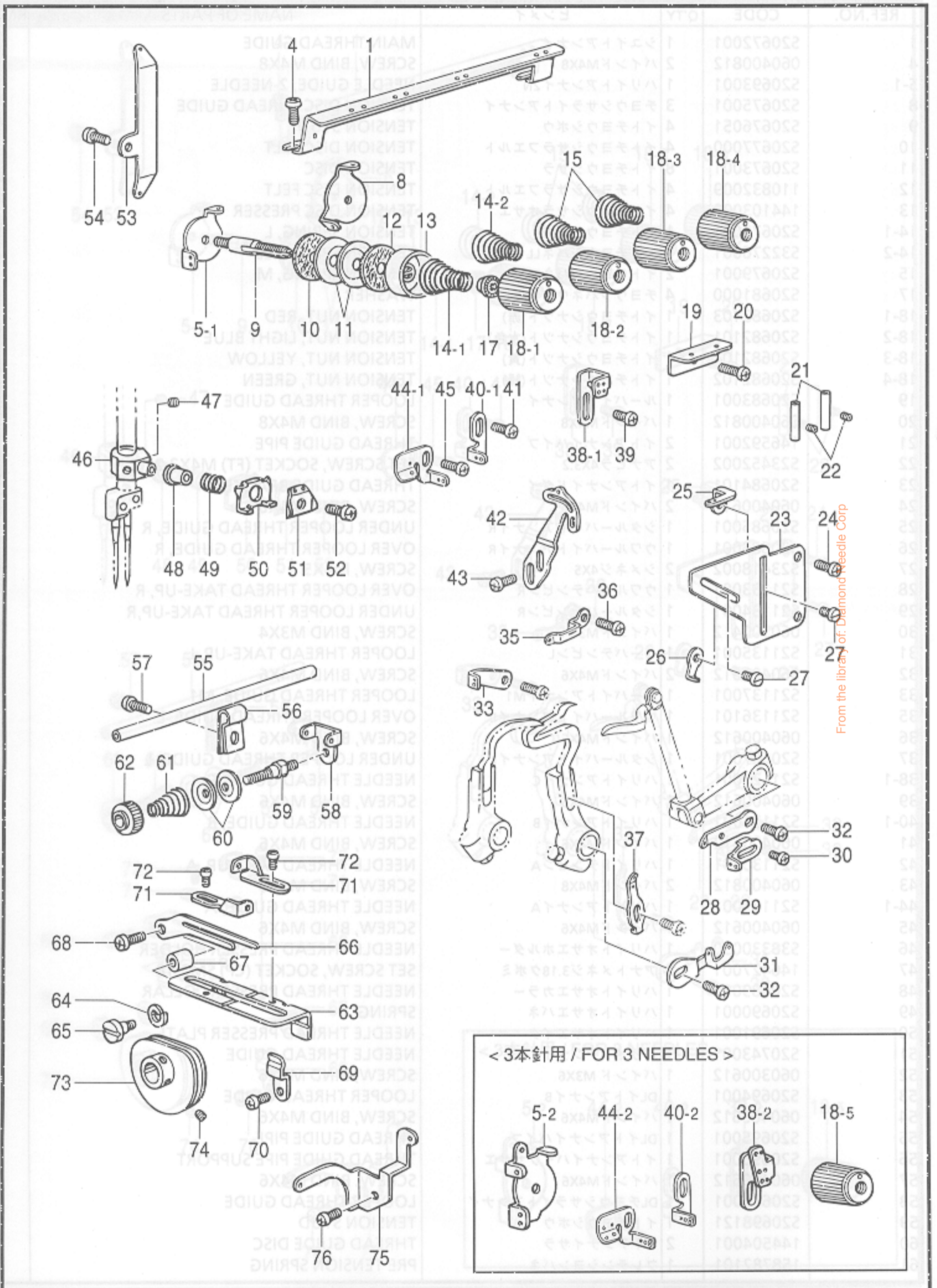

REF.NO.	CODE	Q'TY	ヒンメイ	NAME OF PARTS	RM
62	155510001	1	イトチヨウシナツト	TENSION NUT	
63	S39756021	1	イトサバキドダイ	THREAD HANDLER BRACKET	
64	028050242	1	バネザガネ2-5	WASHER, SPRING 2-5	
65	S20342001	1	ダンネジ4	SHOULDER SCREW, M4	
66	S20701001	1	テンピンイトサバキ	THREAD HANDLER	
67	S39757001	1	カラー	COLLAR	
68	060401412	1	バインドM4X14	SCREW, BIND M4X14	
69	150813001	1	ドダイオサエバネ	SPRING	
70	062350612	1	ナベコM3.5X6	SCREW, PAN M3.5X6	
71	S20702001	2	DLテンピンイトアンナイ	THREAD TAKE-UP GUIDE	
72	S20158101	2	ナベコ2.5X3	SCREW, PAN M2.5X3	
73	S20703051	1	DLテンピンクミ	THREAD TAKE-UP ASSY	
74	S23452002	2	アナヒラ4X3.2	SET SCREW, SOCKET (FT) M4X3.2	
75	S20707001	1	DLイトアンナイA	CHAIN STITCH THREAD GUIDE	
76	060400612	1	バインドM4X6	SCREW, BIND M4X6	

<3本針用>					
5-2	S30121001	1	ハリイトアンナイ3N	NEEDLE GUIDE, 3-NEEDLE	
14-1	S20678001	2	イトチヨウシバネL	TENSION SPRING, L	
18-5	S20682105	1	イトチヨウシナツト(色なし)	TENSION NUT, COLORLESS	
38-2	S30122001	1	ハリイトアンナイC	NEEDLE THREAD GUIDE, C 3-NEED.	
40-2	S21129001	1	ハリイトアンナイB	NEEDLE THREAD GUIDE, B	
44-2	S21128001	1	ハリイトアンナイA	NEEDLE THREAD GUIDE, A	

1	S21336101	1	フチカガリジョウギクミ	EDGE GUIDE ASSY	
1-1	S23890101	1	フチカガリジョウギクミ	EDGE GUIDE SET PLATE	
1-2	S23773001	1	ダンネジ4	SHOULDER SCREW, M4	
1-3	146598001	1	バネザガネ	WASHER, SPRING	
1-4	S23892001	1	ジョウギトリツイタササエ	EDGE GUIDE SUPPORT	
1-5	021400212	2	ジョウギナツト	SCREW, M4	
1-6	S21341001	1	ストツパー	STOPPER	
1-7	062300512	1	ナベコ3X5	SCREW, PAN M3X5	
1-8	146762001	1	フチカガリ	EDGE GUIDE	
1-9	062350612	1	ナベコM3.5X6	SCREW, PAN M3.5X6	
2	062401012	1	ナベコM4X10	SCREW, PAN M4X10	

From the library of: Diamond Needle Corp

P. 針冷却関係 / Needle cooler / Nedelkühlungsvorrichtung / Mécanisme du refroidisseur d'aiguille / Mecanismo del enfriador de aguja

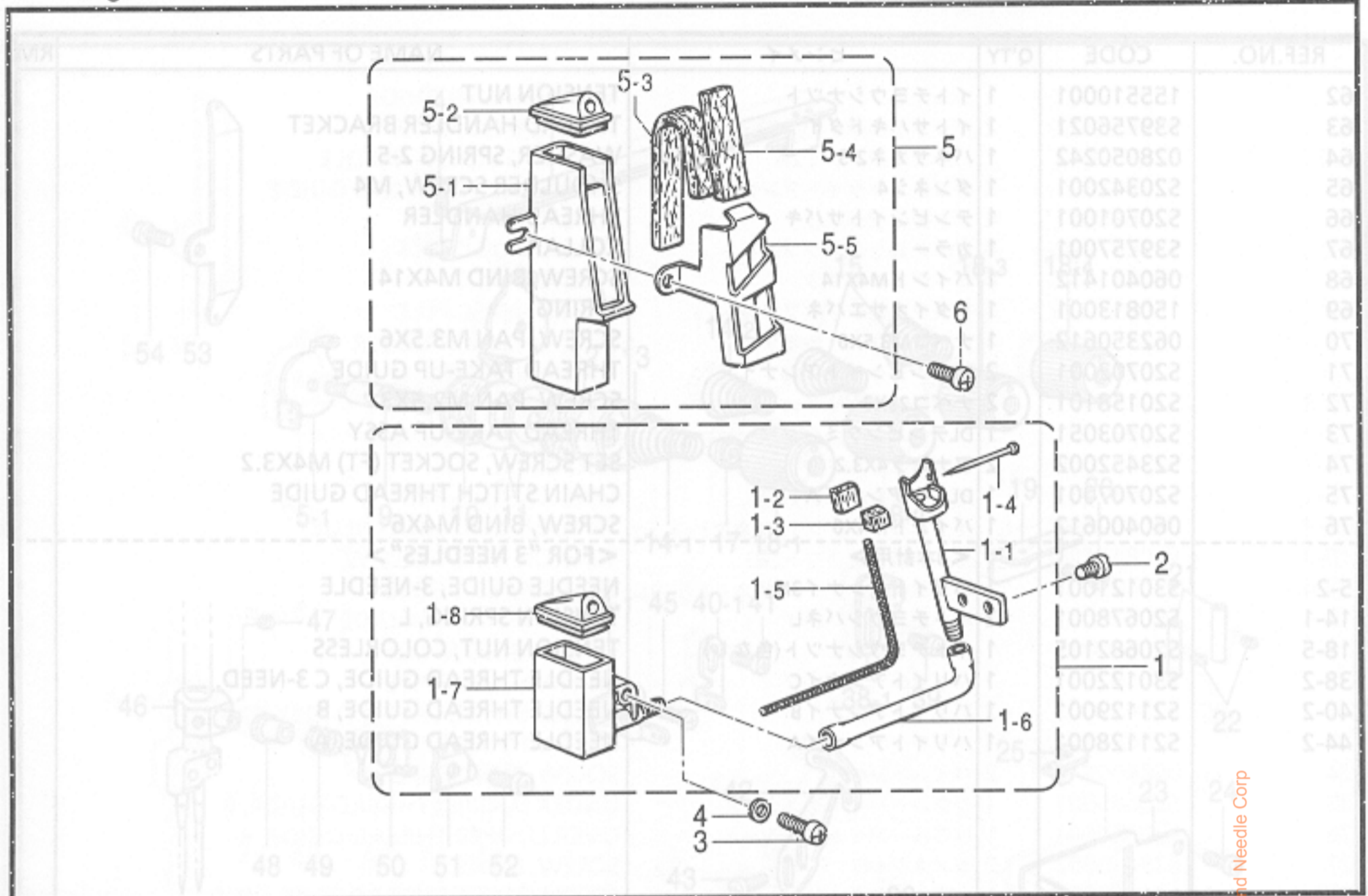

185-V9A,B-124

Q. 縁カガリ定規関係 / Serging attachment / Überwendlichvorrichtung / Accessoire pour couture sur tissus serges / Dispositivo de dobladillo para puntada invisible

オプション部品 / OPTION PARTS

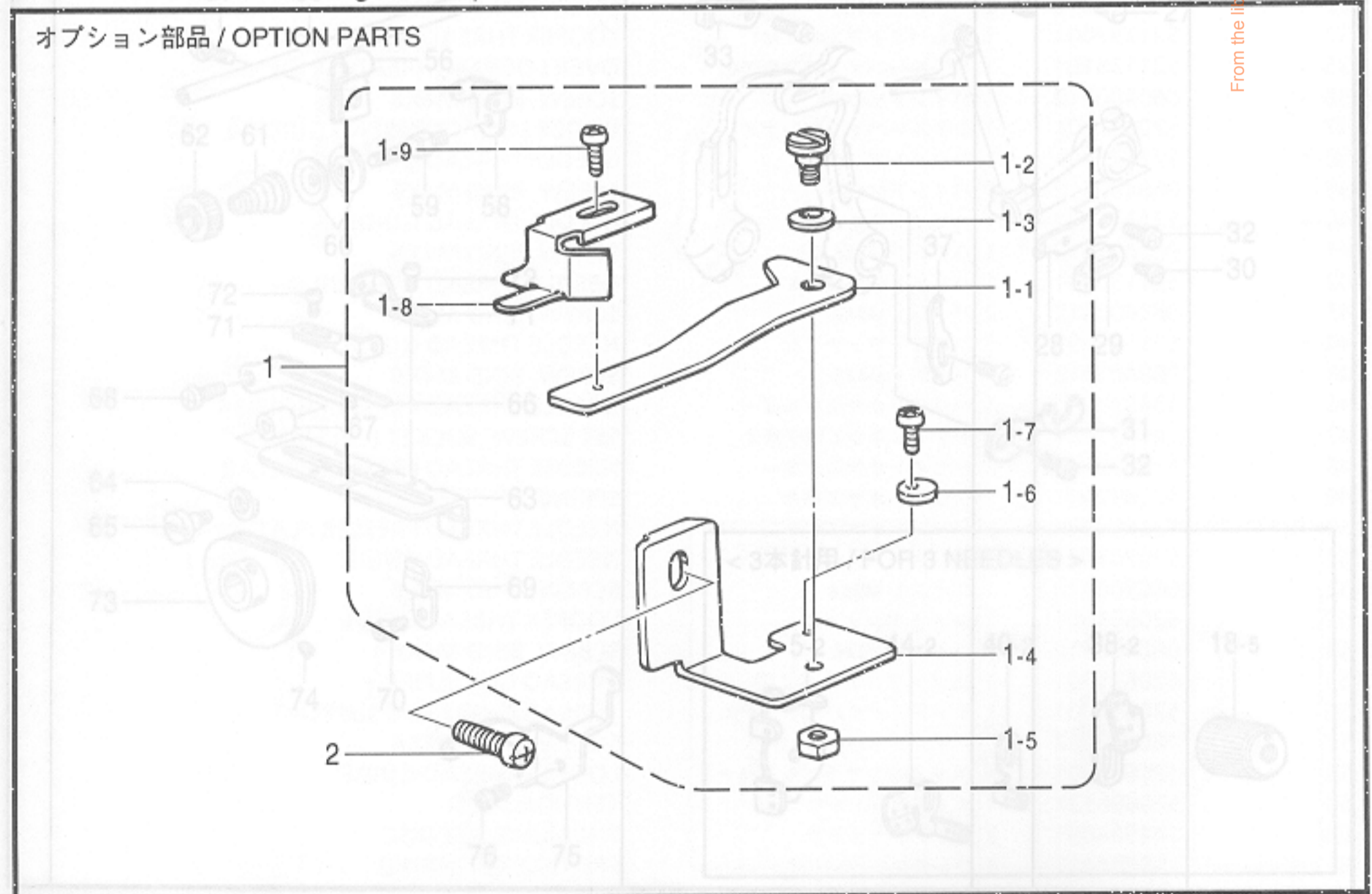

185-V9A,B-236

P. 針冷却関係 / Needle cooler / Nadelkühlungsvorrichtung /
 Mécanisme du refroidisseur d'aiguille / Mecanismo del enfriador de aguja

REF.NO.	CODE	Q'TY	ヒンメイ	NAME OF PARTS	RM
1	S20453001	1	フェルトササエクミ	FELT SUPPORT ASSY	
1-1	S20454000	1	フェルトササエ	FELT SUPPORT	
1-2	S20455000	1	フェルト	FELT	
1-3	S02874001	1	ムシピン	PIN	
1-4	150307000	1	クミヒモ	WICK (L = 140)	
1-5	S20456000	1	ビニルチューブ55	VINYL TUBE 55	
1-6	S20459000	1	シリコンタンクタイL	SILICONE TANK (L)	
1-7	S20460000	1	シリコンタンクフタ	SILICONE TANK CAP	
2	S23418002	2	シメネジ4X5	SCREW, M4X5	
3	060401012	1	バインドM4X10	SCREW, BIND M4X10	
4	025040132	1	ヒラザガネシヨウ4	WASHER, PLAIN S 4	
5	S20461101	1	シリコンタンククミリ	SILICONE TANK ASSY (U)	
5-1	S20464000	1	シリコンタンクU	SILICONE TANK (U)	
5-2	S20460000	1	シリコンタンクフタ	SILICONE TANK CAP	
5-3	S29933000	1	フェルトL	FELT (L)	
5-4	S29934000	1	フェルトS	FELT (S)	
5-5	S20467001	1	フェルトオサエイタ	FELT SUPPORT PLATE	
6	062401012	1	ナベコM4X10	SCREW, PAN M4X10	
2-1-16	S21299001	1	ナベコM4X8	SCREW, PAN M4X8	
2-1-17	S21299001	1	ナベコM4X8	SCREW, PAN M4X8	
2-1-18	S23651002	2	アタリネジ	SET SCREW, SOCKET	
2-1-19	S21300001	1	ナベコM4X10	SCREW, PAN M4X10	
2-1-20	S21060302	1	ナベコM4X10	SCREW, PAN M4X10	
2-1-21	062401612	1	ナベコM4X10	SCREW, PAN M4X10	
2-1-22	021240012	1	ナベコM4X10	SCREW, PAN M4X10	
2-1-23	021240012	1	ナベコM4X10	SCREW, PAN M4X10	
2-1-24	021240012	1	ナベコM4X10	SCREW, PAN M4X10	

185-V9A,B-124

Q. 縁カガリ定規関係 / Serging attachment / Überwendlichvorrichtung /
 Accessoire pour couture sur tissus serges / Dispositivo de dobladillo para puntada invisible

REF.NO.	CODE	Q'TY	ヒンメイ	NAME OF PARTS	RM
1	S21336101	1	フチカガリジヨウギクミ	EDGE GUIDE ASSY	
1-1	S23896101	1	ジヨウギトリツケイタ	EDGE GUIDE SET PLATE	
1-2	S23773001	1	ダンネジ4	SHOULDER SCREW, M4	
1-3	146598001	1	バネザガネ	WASHER, SPRING	
1-4	S23897001	1	ジヨウギトリツケイタササエ	EDGE GUIDE SUPPORT	
1-5	021400212	1	2シユナツト4	NUT, 2 M4	
1-6	S21341001	1	ストツパー	STOPPER	
1-7	062300512	1	ナベコ3X5	SCREW, PAN M3X5	
1-8	146762001	1	フチカガリジヨウギ	EDGE GUIDE	
1-9	062350612	1	ナベコM3.5X6	SCREW, PAN M3.5X6	
2	062401012	1	ナベコM4X10	SCREW, PAN M4X10	
6-5	062350812	2	ナベコ3.5X8	SCREW, PAN M3.5X8	
6-6	S21313001	1	ワイヤートリツケイタ	WIRE SET PLATE	
6-7	S21314001	1	フレキシブルワイヤークミ	FLEXIBLE WIRE ASSY	
6-7-1	021300303	1	ナツト3M6	NUT, 3 M6	
6-8	S23774001	1	ダンネジ3.5	SHOULDER SCREW, M3.5	
6-9	S21315001	1	ナツトM4	STUD, M4	
6-10	021400212	1	ナツト2M4	NUT, 2 M4	
6-11	S21316001	1	ワイヤーストッパー	WIRE STOPPER	
6-12	021240012	1	ナベコM4X10	SCREW, PAN M4X10	

185-V9A,B-236

From the library of: Diamond Needle Corp

R. ラフラー装置関係 / Ruffling attachment / Kräuselvorrichtung / Accessoire pour fronces
 / Accesorio de fruncido

V92A

69
 70
 71
 72
 75
 76
 77
 78

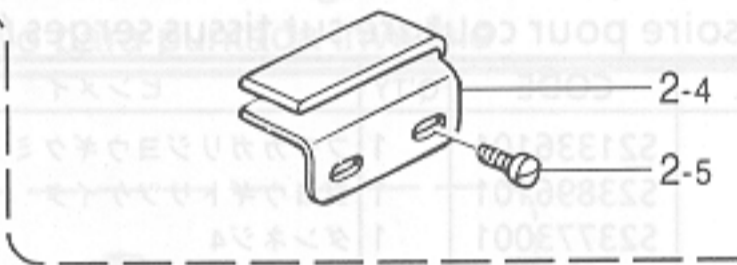
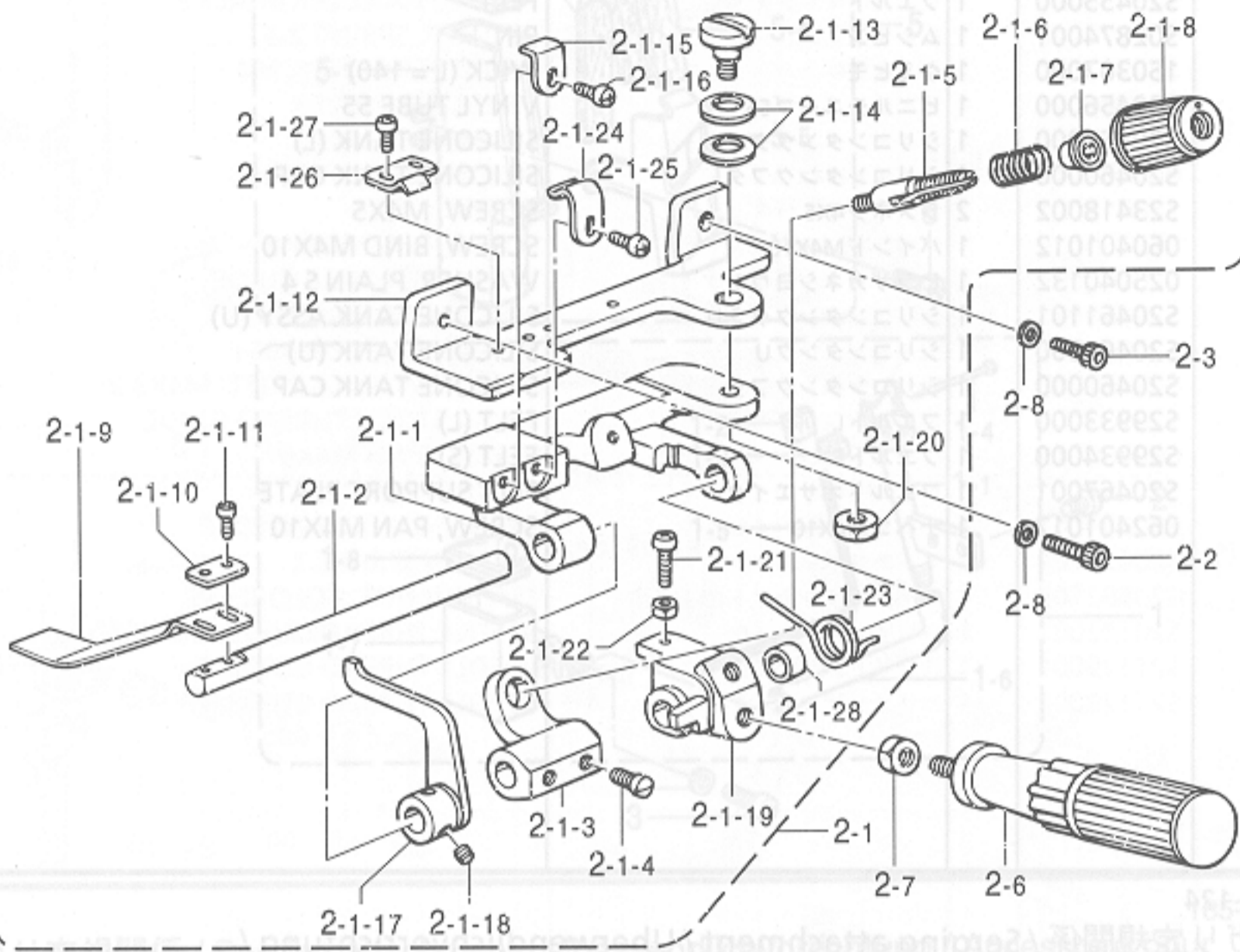

From the library of: Diamond Needle Corp

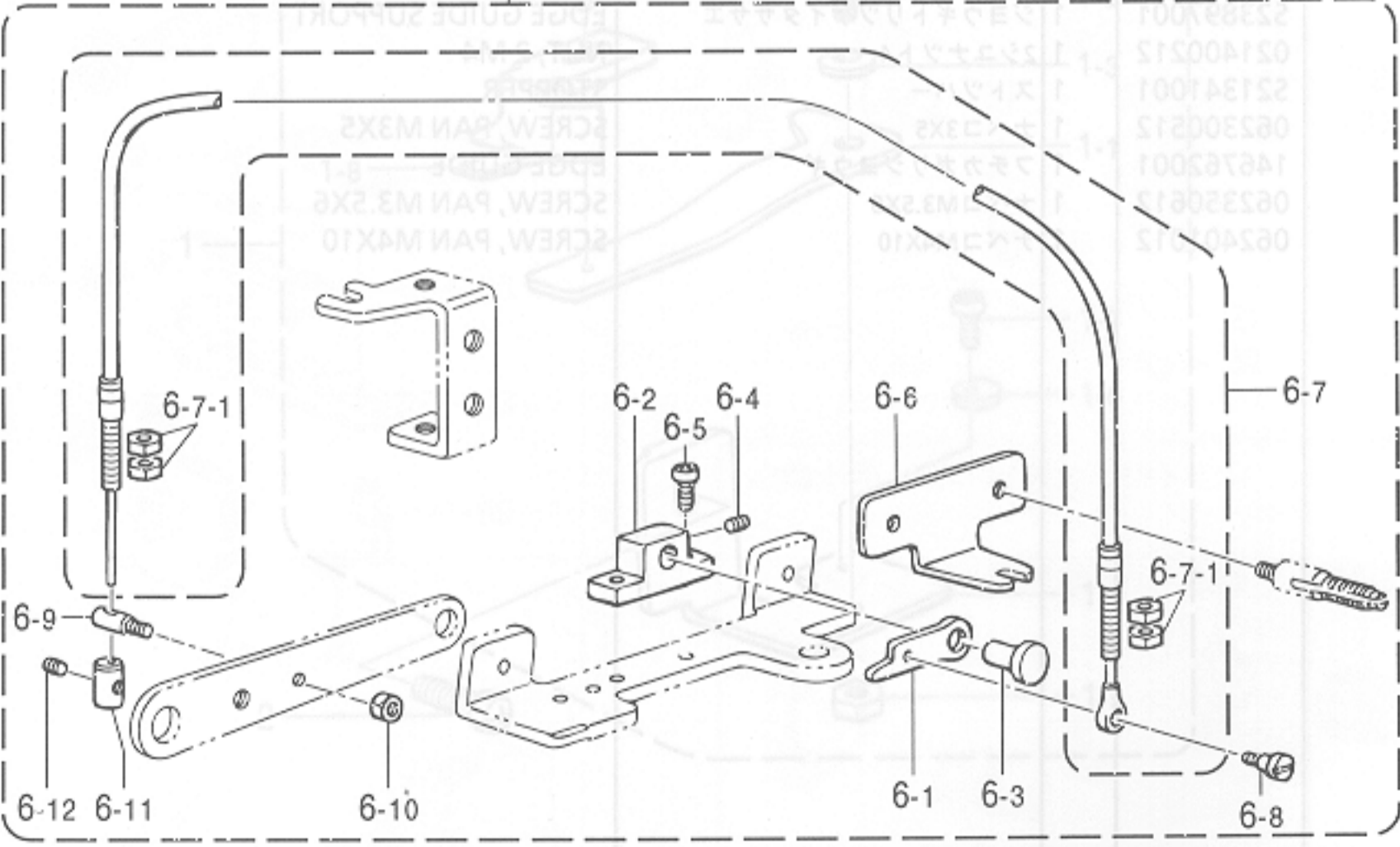

R. ラフラー装置関係 / Ruffling attachment / Kräuselvorrichtung / Accessoire pour fronces /
 Accesorio de fruncido

REF.NO.	CODE	Q'TY	ヒンメイ	NAME OF PARTS	RM
2	S30401001	1	シャーリングクミ	SHIRRING ASSY	
2-1	S21365001	1	シャーリングソウチクミ	SHIRRING DEVICE SET	
2-1-1	S21294001	1	キジオサエタイ	RUFFLING BLADE BRACKET	
2-1-2	S21295001	1	キジオサエトリツケジク	RUFFLING BLADE BASE SHAFT	
2-1-3	S21305001	1	バネウケ	SPRING BASE	
2-1-4	S23777101	2	アタマツキトメネジ6	SET SCREW, M6	
2-1-5	S20676051	1	イトチヨウシボウ	TENSION STUD	
2-1-6	S23775001	1	コイルバネ	SPRING, COIL	
2-1-7	S20681000	1	チヨウシバネウエザガネ	WASHER	
2-1-8	S20682105	1	イトチヨウシナツト	TENSION NUT	
2-1-9	S21366001	1	キジオサエ	RUFFLING BLADE	
2-1-10	144784001	1	キジオサエザガネ	WASHER	
2-1-11	062300812	2	ナベコ3X8	SCREW, PAN M3X8	
2-1-12	S21297001	1	ラフラーソウチトリツケダイ	RUFFLER BASE	
2-1-13	S21306001	1	ダンネジ6	SHOULDER SCREW, M6	
2-1-14	S21307001	2	バネザガネ	WASHER, SPRING	
2-1-15	S21298001	1	キジオサエアンナイ	RUFFLING BLADE GUIDE	
2-1-16	062400812	1	ナベコ4X8	SCREW, PAN M4X8	
2-1-17	S21299001	1	キジオサエアゲ	CLOTH PRESSER BAR LIFTER	
2-1-18	S23651002	2	アナヒラ6X6ホソメ	SET SCREW, SOCKET (FT) M6X5	
2-1-19	S21300001	1	ハンドルトリツケイタ	HANDLE SETTING PLATE	
2-1-20	021060302	1	ナツト3シユ6	NUT, 3 M6	
2-1-21	062401612	1	ナベコM4X16	SCREW, PAN M4X16	
2-1-22	021400212	1	2シユナツト4	NUT, 2 M4	
2-1-23	S21301001	1	ハンドルモドシバネ	SPRING	
2-1-24	S21302001	1	キジオサエタイトメバネU	SPRING, PLATE (U)	
2-1-25	062400612	1	ナベコM4X6	SCREW, PAN M4X6	
2-1-26	S21303001	1	キジオサエタイトメバネD	SPRING, PLATE (D)	
2-1-27	062350512	2	ナベコ3.5X5	SCREW, PAN M3.5X5	
2-1-28	S21304001	1	カラー	COLLAR	
2-2	018401632	1	アナボルト4X16	BOLT, SOCKET M4X16	
2-3	018401032	1	アナボルト4X10	BOLT, SOCKET M4X10	
2-4	S21590000	1	キジオアンナイ	RUFFLER GUIDE	
2-5	S23418002	2	シメネジ4X5	SCREW, M4X5	
2-6	S23779001	1	ハンドル	HANDLE	
2-7	021060302	1	ナツト3シユ6	NUT, 3 M6	
2-8	102707002	2	ザガネ	WASHER, PLAIN 4	
6	S30137001	1	ラフラーオサエレンドウクミ	RUFFLING DEVICE SET	
6-1	S21310001	1	キジオサエアゲレバー	CLOTH PRESSER BAR LIFTER LEVER	
6-2	S21311001	1	オサエアゲダイ	PRESSER BAR LIFTER BRACKET	
6-3	S21312001	1	ピン6.35	PIN, 6.35	
6-4	012060632	1	アナヒラ6X6	SET SCREW, SOCKET (FT) M6X6	
6-5	062350812	2	ナベコ3.5X8	SCREW, PAN M3.5X8	
6-6	S21313001	1	ワイヤートリツケイタ	WIRE SET PLATE	
6-7	S21314001	1	フレキシブルワイヤークミ	FLEXIBLE WIRE ASSY	
6-7-1	021500303	4	ナツト3シユ5	NUT, 3 M5	
6-8	S23774001	1	ダンネジ3.5	SHOULDER SCREW, M3.5	
6-9	S21315001	1	スタツドM4	STUD, M4	
6-10	021400212	1	2シユナツト4	NUT, 2 M4	
6-11	S21316001	1	ワイヤーストツパー	WIRE STOPPER	
6-12	012400432	1	アナヒラ4X4	SET SCREW, SOCKET (FT) M4X4	

From the library of: Diamond Needle Corp

V92A < 半沈用 / FOR SEMI-SUBMERGED >

69
70
71
72
75
76
77
78

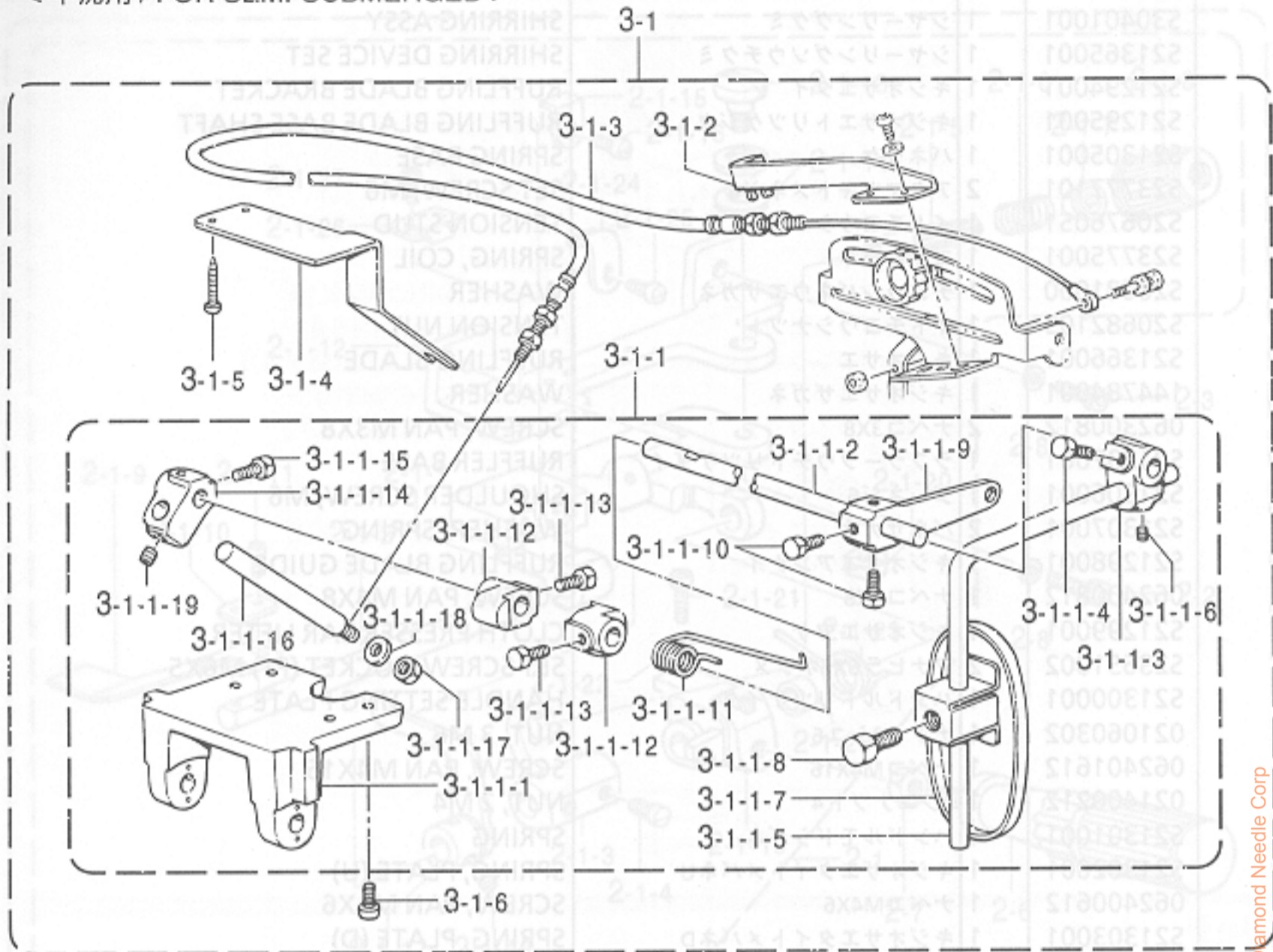

< 全沈用 / FOR FULL-SUBMERGED >

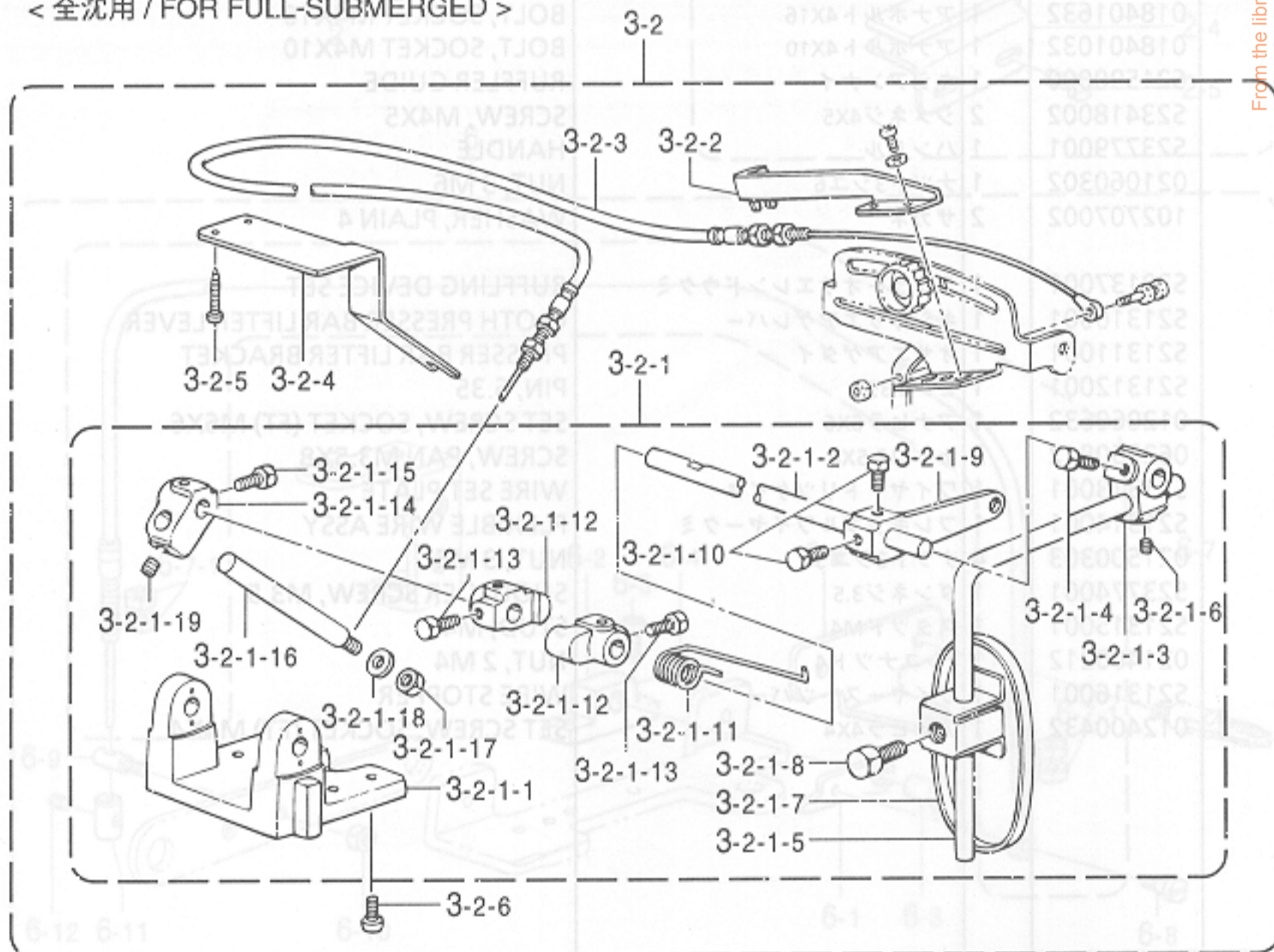

From the library of: Diamond Needle Corp

R. ラフラー装置関係 / Ruffling attachment / Kräuselvorrichtung / Accessoire pour fronces /
 Accesorio de fruncido

REF.NO.	CODE	Q'TY	ヒンメイ	NAME OF PARTS	RM
			<半沈用>	<FOR SEMI-SUBMERGED>	
3-1	S30402101	1	サドウチヨウセツセット	DIFFERENTIAL ADJUSTING SET	
3-1-1	S21387101	1	サドウチヨウセツクミ	DIFFERENTIAL FEED ADJUSTER	
3-1-1-1	155197101	1	ヒザアテヨコジクウケ	KNEE LIFTER SHAFT BRACKET	
3-1-1-2	S21388001	1	ヨコジク	KNEE LIFTER SHAET	
3-1-1-3	155199101	1	ヒザアテツギテ	KNEE LIFTER BRACKET	
3-1-1-4	017781012	2	ボルト6.35X10	BOLT, SM6.35X10	
3-1-1-5	148797001	1	ヒザアゲタテジクS	KNEE LIFTER BAR, S	
3-1-1-6	014780622	1	アナトメネジ6.35クボミ	SET SCREW, SOCKET (CP) SM6.35	
3-1-1-7	148798109	1	ヒザアテL	KNEE LIFTER PLATE, L	
3-1-1-8	017081606	1	ボルト8X16	BOLT, M8X16	
3-1-1-9	S21376001	1	ヒザアテレバー	KNEE LIFTER LEVER	
3-1-1-10	017781012	2	ボルト6.35X10	BOLT, SM6.35X10	
3-1-1-11	S21377001	1	ヒザアテレバーバネ	SPRING	
3-1-1-12	S21378001	2	ヨコジクトメグ	COLLAR	
3-1-1-13	017781012	4	ボルト6.35X10	BOLT, SM6.35X10	
3-1-1-14	155199101	1	ヒザアテツギテ	BRACKET, KNEE LIFTER	
3-1-1-15	017781012	2	ボルト6.35X10	BOLT SM6.35X10	
3-1-1-16	S21382001	1	ワイヤトリツケボウ	WIRE SET BAR	
3-1-1-17	110744002	1	ナツト6.35	NUT SM6.35	
3-1-1-18	025770232	1	ヒラザガネチユウ6.35	WASHER, PLAIN M 6.35	
3-1-1-19	014780622	1	アナトメネジ6.35クボミ	SET SCREW, SOCKET (CP) SM6.35	
3-1-2	S21385001	1	ワイヤトリツケイタ	WIRE SET PLATE	
3-1-3	S21283001	1	フレキシブルワイヤ	FLEXIBLE WIRE	
3-1-4	S21384001	1	ワイヤトリツケイタ	WIRE SET PLATE	
3-1-5	032422505	2	+マルモクネジ4.1X25	WOOD SCREW, ROUND M4.1X25	
3-1-6	062401012	4	ナベコM4X10	SCREW, PAN M4X10	
			<全沈用>	<FOR FULL-SUBMERGED>	
3-2	S30402102	1	サドウチヨウセツセット	DIF. ADJUSTING SET, FULL	
3-2-1	S21374101	1	サドウチヨウセツソウチクミ	DIFFERENTIAL FEED ADJUSTER	
3-2-1-1	155197101	1	ヒザアテヨコジクウケ	KNEE LIFTER SHAFT BRACKET	
3-2-1-2	S21388001	1	ヨコジク	KNEE LIFTER SHAET	
3-2-1-3	155199101	1	ヒザアテツギテ	KNEE LIFTER BRACKET	
3-2-1-4	017781012	2	ボルト6.35X10	BOLT, SM6.35X10	
3-2-1-5	148797001	1	ヒザアゲタテジクS	KNEE LIFTER BAR, S	
3-2-1-6	014780622	1	アナトメネジ6.35クボミ	SET SCREW, SOCKET (CP) SM6.35	
3-2-1-7	148798109	1	ヒザアテL	KNEE LIFTER PLATE, L	
3-2-1-8	017081606	1	ボルト8X16	BOLT, M8X16	
3-2-1-9	S21376001	1	ヒザアテレバー	KNEE LIFTER LEVER	
3-2-1-10	017781012	2	ボルト6.35X10	BOLT, SM6.35X10	
3-2-1-11	S21377001	1	ヒザアテレバーバネ	SPRING	
3-2-1-12	S21378001	2	ヨコジクトメグ	COLLAR	
3-2-1-13	017781012	4	ボルト6.35X10	BOLT, SM6.35X10	
3-1-1-14	155199101	1	ヒザアテツギテ	BRACKET, KNEE LIFTER	
3-1-1-15	017781012	2	ボルト6.35X10	BOLT SM6.35X10	
3-1-1-16	S21382001	1	ワイヤトリツケボウ	WIRE SET BAR	
3-1-1-17	110744002	1	ナツト6.35	NUT SM6.35	
3-1-1-18	025770232	1	ヒラザガネチユウ6.35	WASHER, PLAIN M 6.35	
3-1-1-19	014780622	1	アナトメネジ6.35クボミ	SET SCREW, SOCKET (CP) SM6.35	
3-1-2	S21385001	1	ワイヤトリツケイタ	WIRE SET PLATE	
3-1-3	S21283001	1	フレキシブルワイヤ	FLEXIBLE WIRE	
3-1-4	S21384001	1	ワイヤトリツケイタ	WIRE SET PLATE	
3-1-5	032422505	2	+マルモクネジ4.1X25	WOOD SCREW, ROUND M4.1X25	
3-2-6	062401012	4	ナベコM4X10	SCREW, PAN M4X10	

From the library of: Diamond Needle Corp

V92A
 75
 76
 77
 78

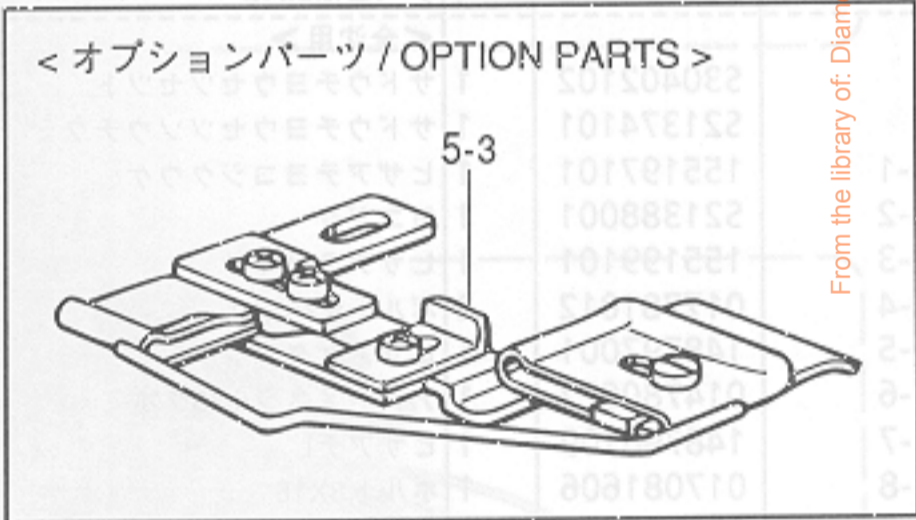
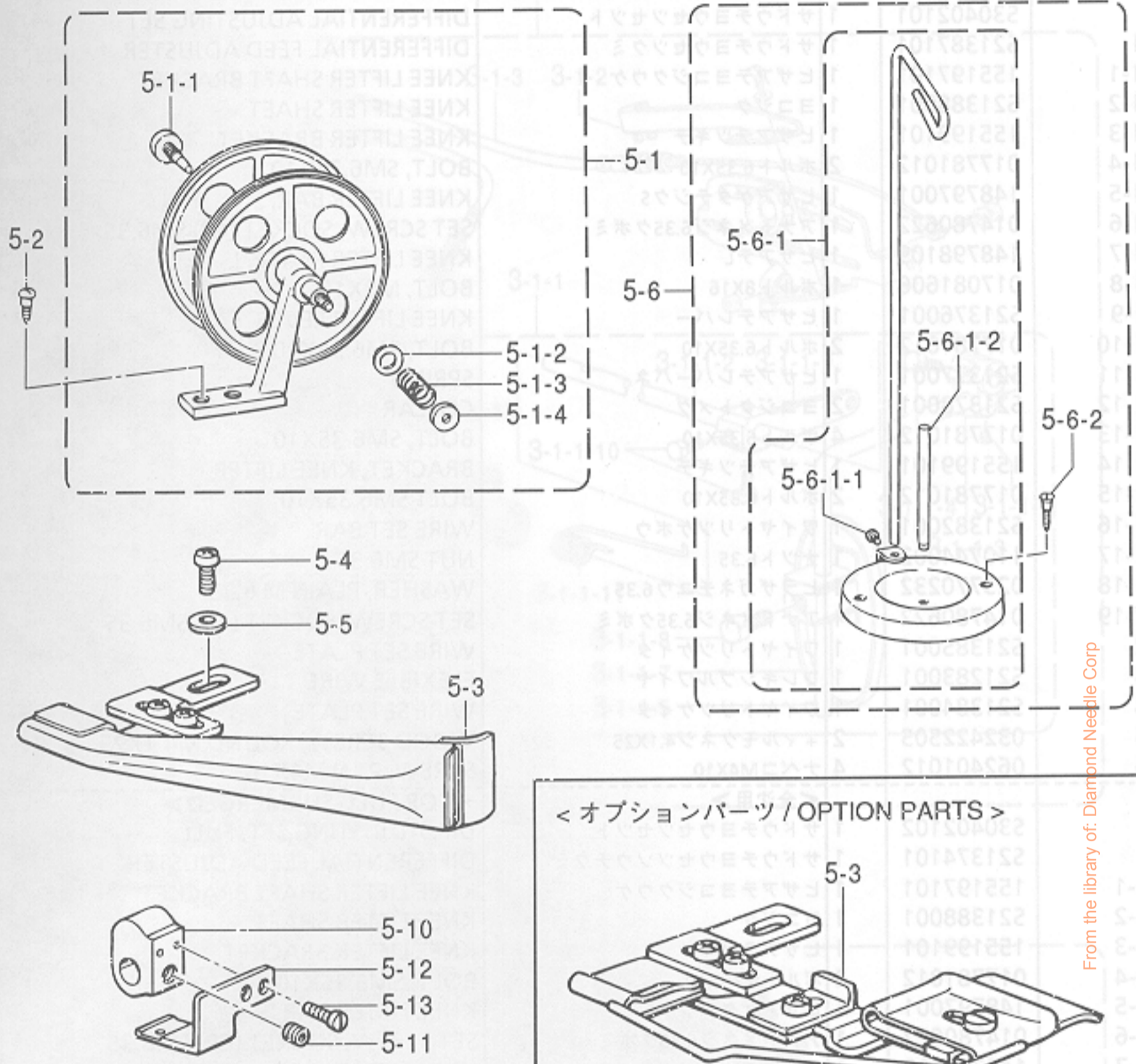

From the library of: Diamond Needle Corp

V92A
 69
 70
 71
 72
 75
 76
 77
 78

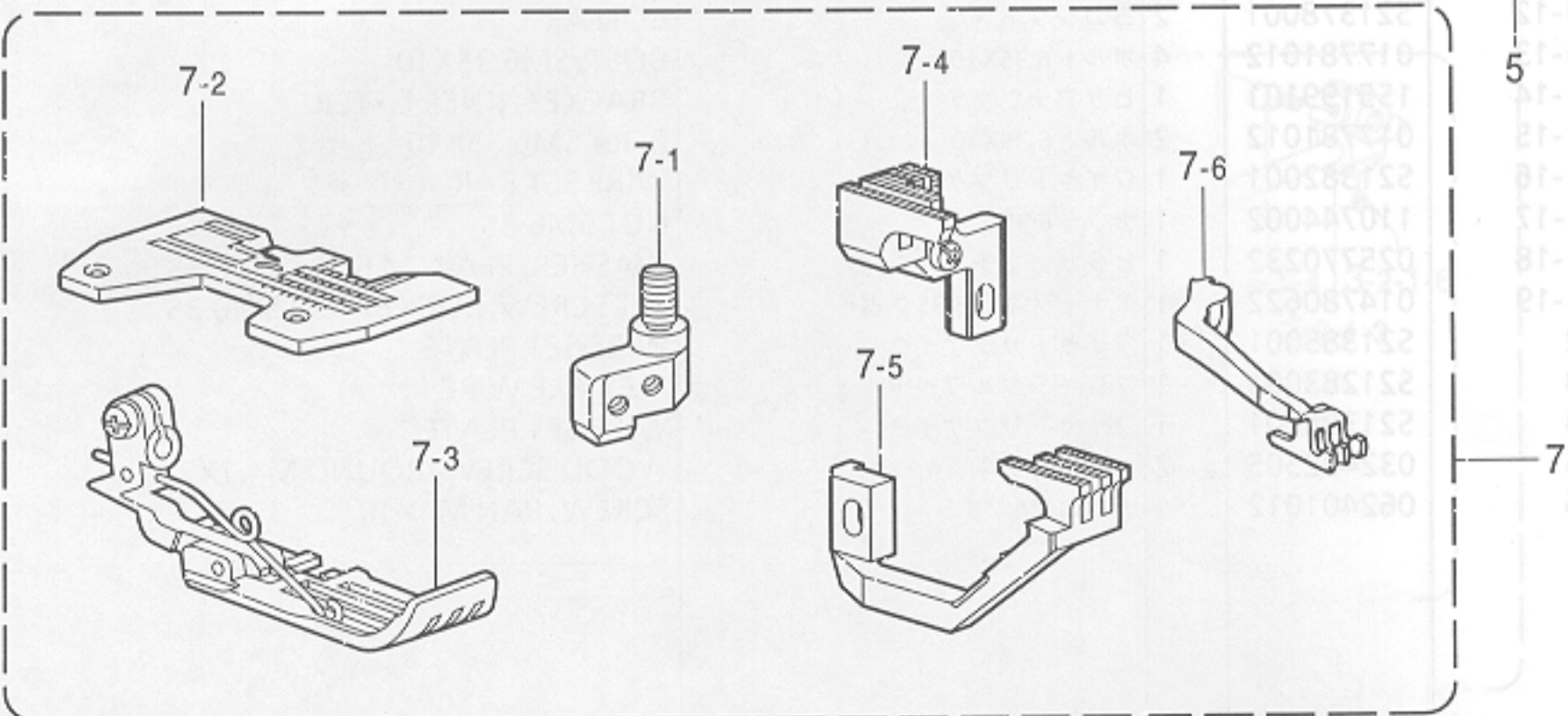

R. ラフラー装置関係 / Ruffling attachment / Kräuselvorrichtung / Accessoire pour fronces /
 Accesorio de fruncido

REF.NO.	CODE	Q'TY	ヒンメイ	NAME OF PARTS	RM
5	S30404001	1	パイピングパーツミ	PIPING PARTS ASSY	
5-1	143767002	1	テープワインダークミ	TAPE WINDER ASSY	
5-1-1	143980001	1	ツマミネジ	SCREW	
5-1-2	108494001	1	ザガネ	WASHER	
5-1-3	108495001	1	テープワインダオシバネ	SPRING	
5-1-4	100136001	1	イトチヨウシナツト	TENSION NUT	
5-2	101118001	2	マルモクネジ4.5X20	WOOD SCREW, ROUND M4.5X20	
5-3	S21370001	1	ラツハークミ	LAPPER ASSY	
<オプション>					
5-3	S21372001	1	ラツハークミ	LAPPER ASSY	
5-4	062350612	1	ナベコM3.5X6	SCREW, PAN M3.5X6	
5-5	025350332	1	ヒラザガネダイ3.5	WASHER, PLAIN L 3.5	
5-6	S20130009	1	イトタテダイクミネジツキ	COTTON STAND ASSY, W/SCREW	
5-6-1	S20131009	1	イトタテダイクミ	COTTON STAND ASSY	
5-6-1-1	S20134001	1	シメネジW476-24X10	SCREW, W4.76-24X10	
5-6-1-2	S20135001	1	イトタテボウ	SPOOL PIN	
5-6-2	034422006	2	+2サラモク41X20	WOOD SCREW, FLAT 2 M4.1X20	
5-10	S21368001	1	ラツハードダイ	LAPPER BASE	
5-11	S23651002	1	アナヒラ6X6ホソメ	SET SCREW, SOCKET (FT) M6X5	
5-12	S21369001	1	ラツハートリツケイタ	LAPPER SET PLATE	
5-13	S20355002	2	シメネジ3X8.5	SCREW, M3X8.5	
7		1	シャーリングゲージクミ	SHIRRING GAUGE ASSY	
<パイピング用>					
7		1	P.シャーリングゲージクミ	PIPING SHIRRING GAUGE ASSY	
7-1	※		ハリドメクミ	NEEDLE GAUGE ASSY	
7-2	※	1	ハリイタ	NEEDLE PLATE	
7-3	※	1	オサエクミ	PRESSER FOOT ASSY	
7-4	※	1	シユオクリバクミ	MAIN FEED DOG ASSY	
7-5	※	1	サドウオクリバ	DIFFERENTIAL FEED DOG	
7-6	※	1	ウワオクリバ	UPPER FEED DOG	

From the library of: Diamond Needle Corp

V92A	REF.NO.	69、70-4		69、70-5	
		半沈 Semi- Submerged	全沈 Full- Submerged	半沈 Semi- Submerged	全沈 Full- Submerged
シャーリングシヨウセット/SHIRRING SET		S30413103	S31115103	S30413104	S31115104
シャーリングゲージクミ/SHIRRING GAUGE ASSY	7	S30411003	←	S30411004	←
シャーリングクミ/SHIRRING ASSY	2	S30401001	←	←	←
サドウチョウセツセット/DIFFERENTIAL ADJUSTING SET	3	S30402101	S30402102	S30402101	S30402102
ラフラーオサエレンドウクミ/RUFFLING DEVICE SET	6	S30137001	←	←	←

V92A	REF.NO.	71、72-5		71、72-6	
		半沈 Semi- Submerged	全沈 Full- Submerged	半沈 Semi- Submerged	全沈 Full- Submerged
シャーリングシヨウセット/SHIRRING SET		S30413105	S31115105	S30413106	S31115106
シャーリングゲージクミ/SHIRRING GAUGE ASSY	7	S30411005	←	S30411006	←
シャーリングクミ/SHIRRING ASSY	2	S30401001	←	←	←
サドウチョウセツセット/DIFFERENTIAL ADJUSTING SET	3	S30402101	S30402102	S30402101	S30402102
ラフラーオサエレンドウクミ/RUFFLING DEVICE SET	6	S30137001	←	←	←

V92A	REF.NO.	75、76-5		77、78-5		77、78-6	
		半沈 Semi- Submerged	全沈 Full- Submerged	半沈 Semi- Submerged	全沈 Full- Submerged	半沈 Semi- Submerged	全沈 Full- Submerged
P. シャーリングシヨウセット/PIPING SHIRRING SET		S30414104	S31116104	S30414105	S31116105	S30414106	S31116106
P. シャーリングゲージクミ/PIPING SHIRRING GAUGE ASSY	7	S30412004	←	S30412005	←	S30412006	←
シャーリングクミ/SHIRRING ASSY	2	S30401001	←	←	←	←	←
サドウチョウセツセット/DIFFERENTIAL ADJUSTING SET	3	S30402101	S30402102	S30402101	S30402102	S30402101	S30402102
パイピングパーツクミ/PIPING PARTS ASSY	5	S30404001	←	←	←	←	←
ラフラーオサエレンドウクミ/RUFFLING DEVICE SET	6	S30137001	←	←	←	←	←

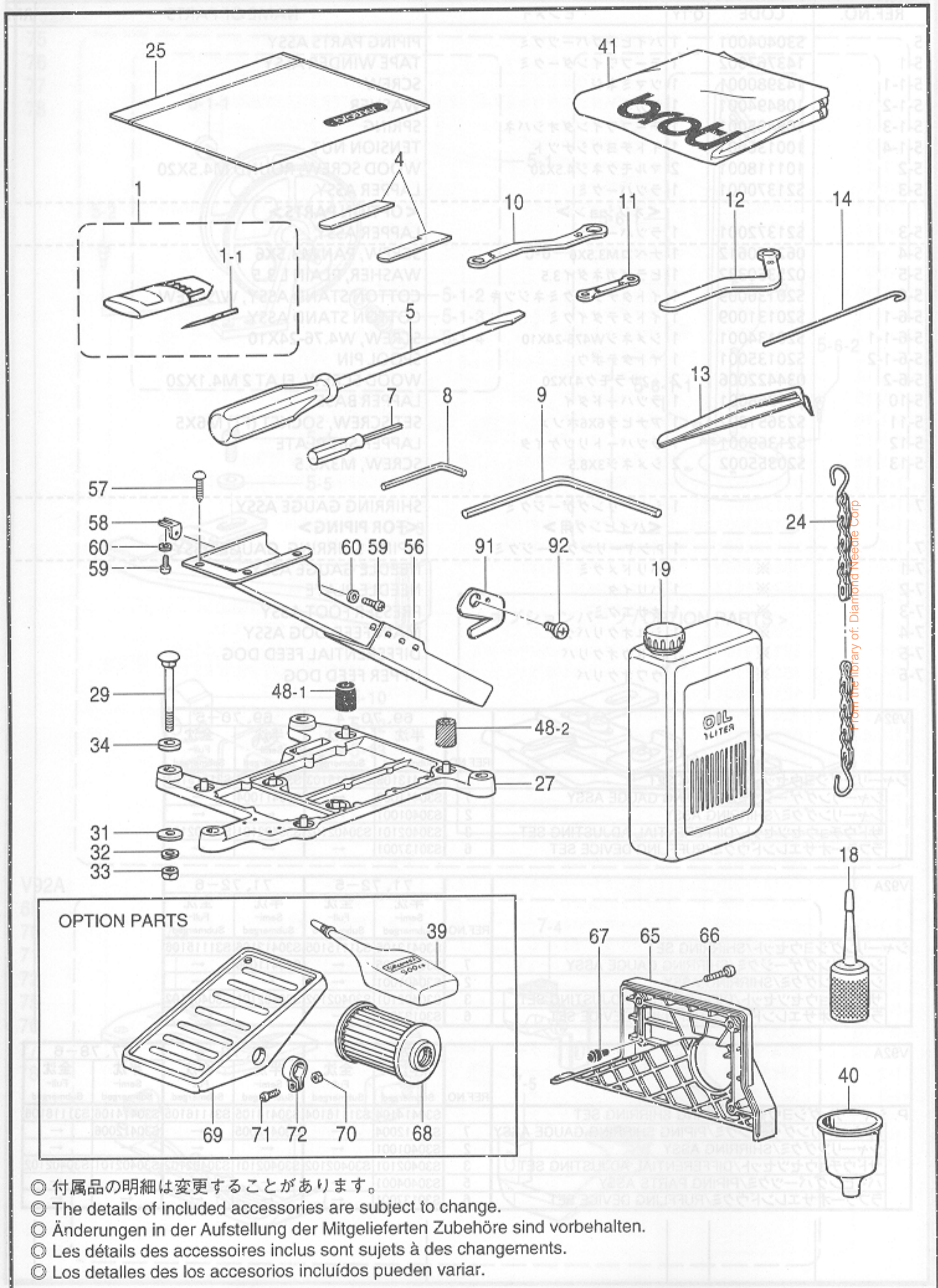

◎ 付属品の明細は変更することがあります。
 ◎ The details of included accessories are subject to change.
 ◎ Änderungen in der Aufstellung der Mitgelieferten Zubehöre sind vorbehalten.
 ◎ Les détails des accessoires inclus sont sujets à des changements.
 ◎ Los detalles de los accesorios incluidos pueden variar.

REF.NO.	CODE	Q'TY	ヒンメイ	NAME OF PARTS	RM
42-1	S29855109	2	ミシンハリクミ	NEEDLE ASSY, DCX27	
42-1-1	150180001	8	ミシンハリ	NEEDLE, DCX27	
42-1-2	S20582001	1	シタメス <T1.5>	LOWER KNIFE <T1.5>	
2-1-3	101572101	1	ネジマワシ5.5X190	SCREW DRIVER, 5.5X190	
2-1-4	S01943001	1	6カクボウネジマワシ1.6	SCREW DRIVER, HEX. 1.6	
2-1-4-1	142002001	1	6カクボウスパナ2	HEXAGONAL WRENCH, 2	
2-1-4-2	149570001	1	6カクボウスパナ5	HEXAGONAL WRENCH, 5	
1-5	S23356001	1	メガネレンチ8X10	DOUBLE WRENCH, 8X10	
1-6	S46907001	1	メガネレンチ5X6	DOUBLE WRENCH, 5X6	
1-7	S20723001	1	メガネレンチ8	WRENCH, 8	
1-7-1	117466000	1	ピンセット	PINCETTE	
1-8	S24473000	1	イトトオシ	THREADER	
1-9	S06701000	1	ポリオイラークミ	POLY OILER ASSY	
1-10	145277205	1	オイルタンク	OIL TANK	
1-10-1	142262001	1	クサリフクミ	CHAIN, F ASSY	
1-10-2	122991001	1	フゾクヒンポリフクロ	ACCESSORY BAG	
1-10-3	S20718000	1	トウブウケ	HEAD PLATE	
1-11	S35997001	4	カクネボルト8X85	BOLT, M8X85	
1-12	213650001	4	ワ2.3X8.5X38ST	WASHER, 2.3X8.5X38ST	
1-13	028080242	4	バネザガネ2-8	WASHER, SPRING 2-8	
1-14	021080106	4	ナツト1シユ8	NUT, 1 M8	
1-15	S20719000	4	クツシヨン	CUSHION	
1-16	S06704001	1	シリコンオイル	-----	
1-17	S20769000	1	ジョーゴ	FUNNEL	
1-18	144225002	1	トウブカバー	HEAD COVER	
1-18-1	147919051	1	ボウシンゴム	RUBBER CUSHION	
1-18-2	147919052	3	ボウシンゴム	RUBBER CUSHION	
1-18-3	183797009	1	ダスターシュートクミ	DUSTER CHUTE ASSY	
1-18-4	031411304	3	マルモクネジ4.1X13	WOOD SCREW, ROUND M4.1X13	
1-19	S23353001	1	ダスターシュートササエS	DUSTER SHOOT SUPPORT, S	
1-19-1	062400612	2	ナベコM4X6	SCREW, PAN M4X6	
1-19-2	025040332	2	ヒラザガネダイ4	WASHER, PLAIN L 4	
1-19-3	S38645001	1	ベルトカバークミ	BELT COVER ASSY	
1-20	062061412	3	ナベコ6X14	SCREW, PAN M6X14	
1-20-1	S20412000	1	ゴムセン3.7	RUBBER CAP, 3.7	
1-20-2	S08956100	1	オイルフィルター	-----	
1-20-3	147893009	1	オサエアゲフミイタ	-----	
1-21	021400106	2	ナツト1シユ4	-----	
1-21-1	062401406	2	ナベコ4X14	-----	
1-21-2	116016001	2	ヘタルトメ	-----	
1-21-3	S20118151	1	カラヌイメス	TRIMMING KNIFE	
92	060300512	1	<V91A> バインドM3X5	<V91A> SCREW, BIND M3X5	
92	060300412	1	<V92A> バインドM3X4	<V92A> SCREW, BIND M3X4	
39	S06704001	1	-----	<OPTION PARTS> SILICONE OIL	
68	S08956100	1	-----	OIL FILTER	
69	147893009	1	-----	TREADLE PEDAL	
70	021400106	2	-----	NUT, 1 M4	
71	062401406	2	-----	SCREW, PAN M4X14	
72	116016001	2	-----	PEDAL STOPPER	

From the library of: Diamond Needle Corp

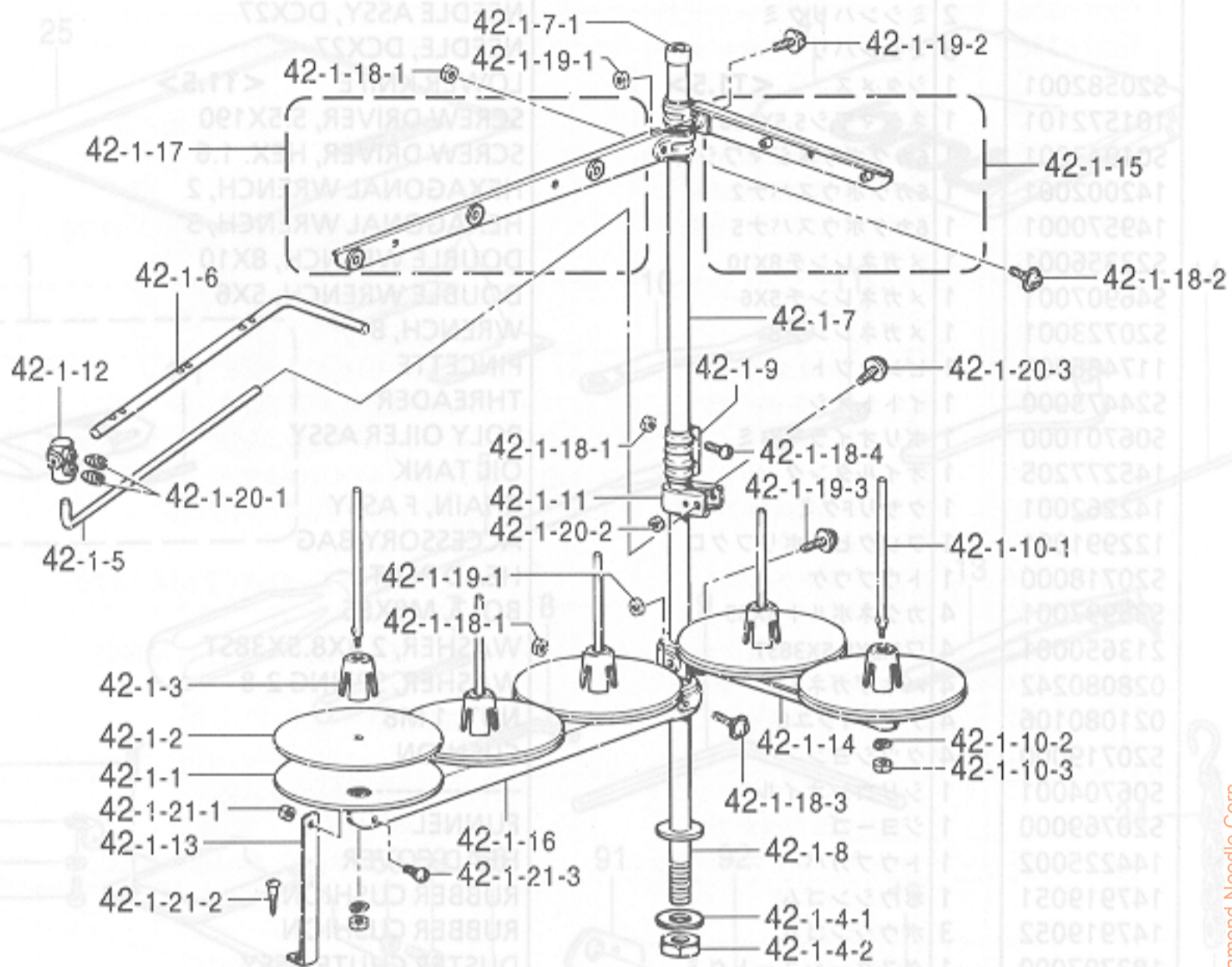

オプション部品 / OPTION PARTS

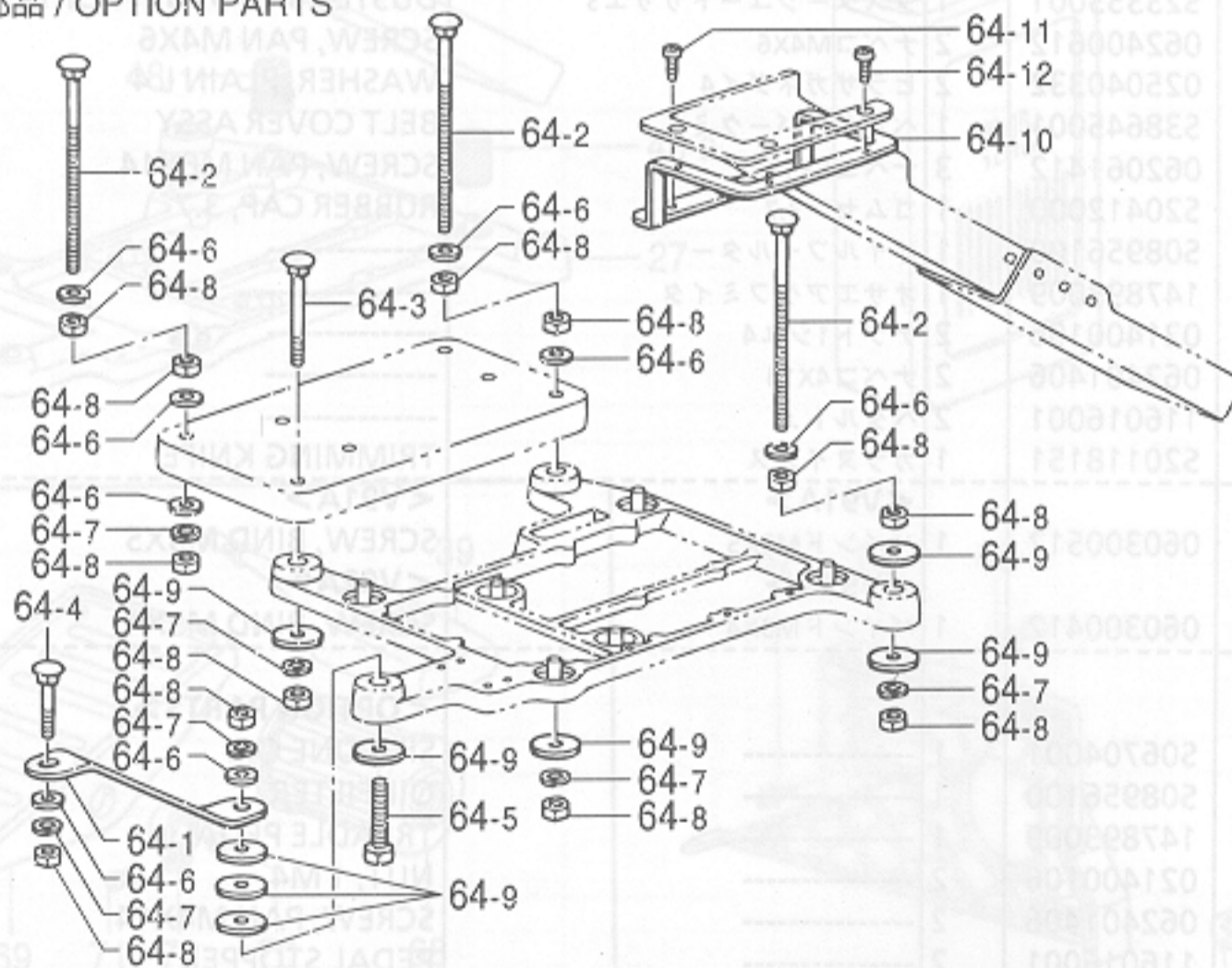

- ◎ 付属品の明細は変更することがあります。
- ◎ The details of included accessories are subject to change.
- ◎ Änderungen in der Aufstellung der Mitgelieferten Zubehöre sind vorbehalten.
- ◎ Les détails des accessoires inclus sont sujets à des changements.
- ◎ Los detalles de los accesorios incluidos pueden variar.

From the library of: Diamond Needle Corp

REF.NO.	CODE	Q'TY	ヒンメイ	NAME OF PARTS	RM
42-1	S29855109	1	イトタテダイクミ5DTHF	COTTON STAND ASSY, 5DTHF	
42-1-1	150180001	5	ウケザラ	SPOOL STAND BASE	
42-1-2	150182000	5	スプールマット	SPOOL MAT	
42-1-3	126863001	5	スプールのクッション	SPOOL CUSHION	
42-1-4	S02775001	1	パイプネジセットA	PIPE SCREW SET, A	
42-1-4-1	150206002	1	ヒラザガネ16	WASHER, PLAIN 16	
42-1-4-2	S38648001	1	6カクナツトU5/8	NUT, U5/8-28	
42-1-5	S04109001	1	イトアンナイササエボウ	THREAD GUIDE SUPPORT BAR	
42-1-6	142999101	1	イトアンナイ5	THREAD GUIDE, 5	
42-1-7	S40640001	1	コラムパイプキヤツブツキ	COLUMN PIPE WITH CAP	
42-1-7-1	150174000	1	コラムキヤツブ	COLUMN CAP	
42-1-8	156112003	1	コラムパイプD	COLUMN PIPE, D	
42-1-9	150173003	1	コラムジョイント	COLUMN JOINT	
42-1-10	S21798001	5	スプールネジセット	SPOOL SCREW SET	
42-1-10-1	150179002	5	スプールジクB	SPOOL SHAFT, B	
42-1-10-2	028050246	5	バネザガネ2-5	WASHER, SPRING 2-5	
42-1-10-3	021500106	5	1シユナツト5	NUT, 1 M5	
42-1-11	150185009	1	イトアンナイホルダー	THREAD GUIDE HOLDER	
42-1-12	138843001	1	ササエボウツギテ	JOINT	
42-1-13	150188009	1	スプールホルダーササエA	SPOOL HOLDER SUPPORT, A	
42-1-14	S02778002	1	スプールホルダー2	SPOOL HOLDER, 2	
42-1-15	S02786002	1	スレツドハンガークミ2	THREAD HANGER ASSY, 2	
42-1-16	S02779009	1	スプールホルダー3	SPOOL HOLDER, 3	
42-1-17	S02788009	1	スレツドハンガークミ3	THREAD HANGER ASSY, 3	
42-1-18	S40641001	1	スプールジクネジセットA	SPOOL SCREW SET, A	
42-1-18-1	021500106	4	1シユナツト5	NUT, 1 M5	
42-1-18-2	S37038001	1	ナベコヒラザ5X14	SCREW, PAN (S/P WASHER) M5X14	
42-1-18-3	S37037001	1	ナベコヒラザ5X32	SCREW, PAN (S/P WASHER) M5X32	
42-1-18-4	062501406	2	ナベコ5X14	SCREW, PAN M5X14	
42-1-19	S40642001	1	スプールジクネジセットB	SPOOL SHAFT SCREW SET, B	
42-1-19-1	021500106	2	1シユナツト5	NUT, 1 M5	
42-1-19-2	S37038001	1	ナベコヒラザ5X14	SCREW, PAN (S/P WASHER) M5X14	
42-1-19-3	S37037001	1	ナベコヒラザ5X32	SCREW, PAN (S/P WASHER) M5X32	
42-1-20	S40643001	1	ホルダーツギテネジセット	HOLDER JOINT SCREW SET	
42-1-20-1	014060632	2	アナトメ6X6クボミ	SET SCREW, SOCKET (CP) M6X6	
42-1-20-2	021500106	1	1シユナツト5	NUT, 1 M5	
42-1-20-3	S37037001	1	ナベコヒラザ5X32	SCREW, PAN (S/P WASHER) M5X32	
42-1-21	S40644001	1	ホルダーツギテネジセット	HOLDER JOINT SCREW SET	
42-1-21-1	021500106	1	1シユナツト5	NUT, 1 M5	
42-1-21-2	031452206	1	マルモク45X22	WOOD SCREW, ROUND M4.5X22	
42-1-21-3	062501006	1	ナベコ5X10	SCREW, PAN M5X10	
64	183798001	1	フルサブマージセット	FULL SUBMERGED SET	
64-1	S20721001	1	トウブウケササエ	HEAD PLATE SUPPORT	
64-2	153318201	4	カクネマルアタマボルト	BOLT	
64-3	S35997001	1	カクネボルト8X85	BOLT, M8X85	
64-4	S36007001	1	カクネボルト8X55	BOLT, M8X55	
64-5	017085502	1	ボルトM8X55	BOLT, M8X55	
64-6	025080236	11	ヒラザガネチユウ8	WASHER, PLAIN M 8	
64-7	028080242	7	バネザガネ2-8	WASHER, SPRING 2-8	
64-8	021080106	15	ナツト1シユ8	NUT, 1 M8	
64-9	213650001	8	ワ2.3X8.5X38ST	WASHER, 2.3X8.5X38ST	
64-10	S20722001	1	ダスターシュートササエL	DUSTER SHOOT SUPPORT, L	
64-11	060400812	2	バインドM4X8	SCREW, BIND M4X8	
64-12	060400812	3	バインドM4X8	SCREW, BIND M4X8	

From the library of: Diamond Needle Corp

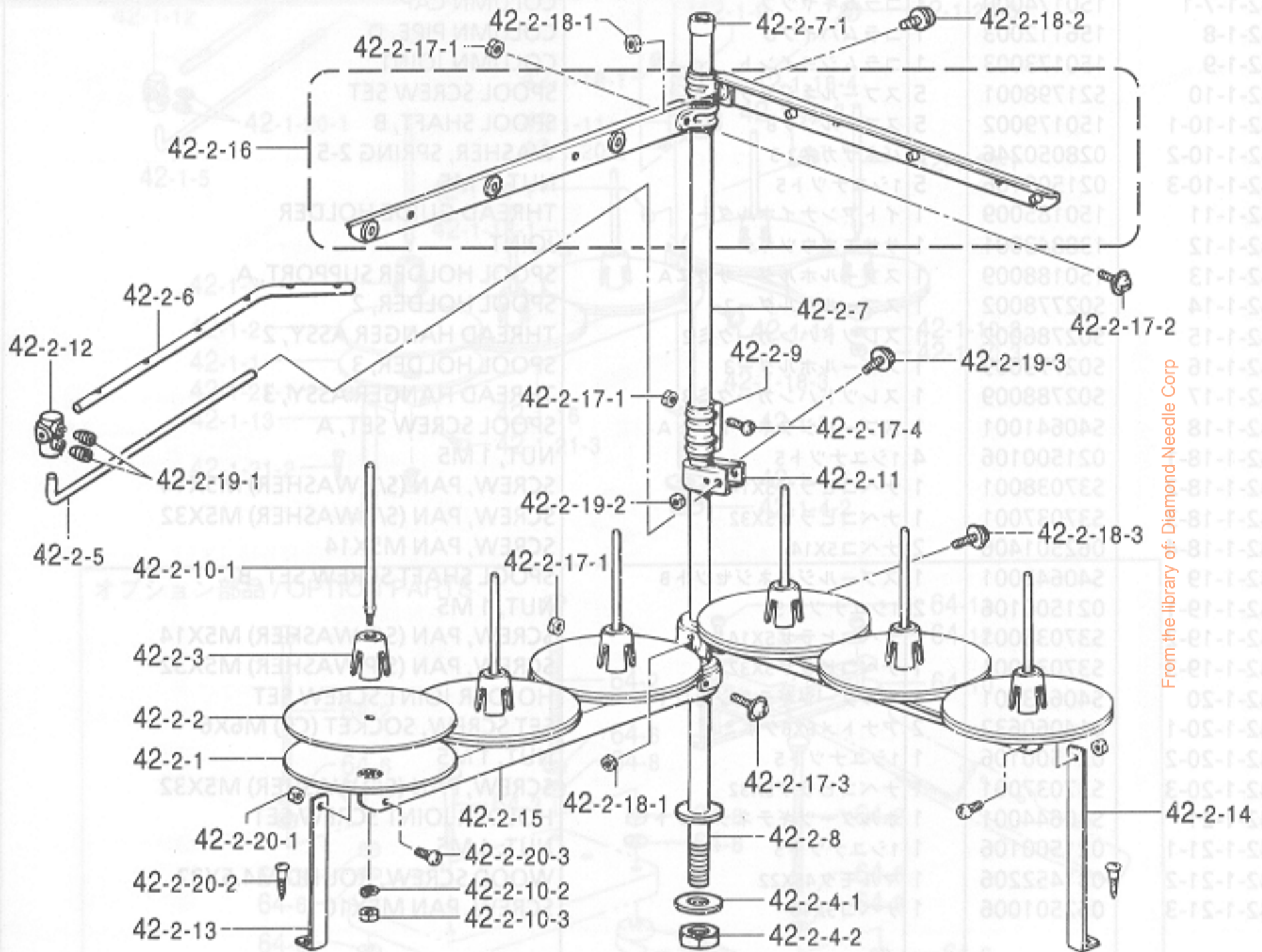

From the library of: Diamond Needle Corp



















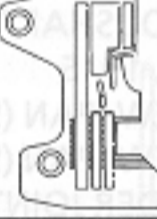



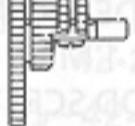
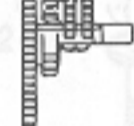
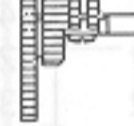



- ◎ 付属品の明細は変更することがあります。
- ◎ The details of included accessories are subject to change.
- ◎ Änderungen in der Aufstellung der Mitgelieferten Zubehöre sind vorbehalten.
- ◎ Les détails des accessoires inclus sont sujets à des changements.
- ◎ Los detalles de los accesorios incluidos pueden variar.

Z. 付属品関係 / Accessories / Zubehör / Accessoires / Accesorios

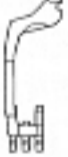
REF.NO.	CODE	Q'TY	ヒンメイ	NAME OF PARTS	RM
42-2	S29864109	1	イトタテダイクミ6DTHF	COTTON STAND ASSY, 6DTHF	
42-2-1	150180001	6	ウケザラ	SPOOL STAND BASE	
42-2-2	150182000	6	スプールマット	SPOOL MAT	
42-2-3	126863001	6	スプールのクッション	SPOOL CUSHION	
42-2-4	S02775001	1	パイプネジセットA	PIPE SCREW SET, A	
42-2-4-1	150206002	1	ヒラザガネ16	WASHER, PLAIN 16	
42-2-4-2	S38648001	1	6カクナットU5/8	NUT, U5/8-28	
42-2-5	S04109001	1	イトアンナイササエボウ	THREAD GUIDE SUPPORT BAR	
42-2-6	S02783001	1	イトアンナイ6	THREAD GUIDE, 6	
42-2-7	S40640001	1	コラムパイプキャップツッキ	COLUMN PIPE WITH CAP	
42-2-7-1	150174000	1	コラムキャップ	COLUMN CAP	
42-2-8	156112003	1	コラムパイプD	COLUMN PIPE, D	
42-2-9	150173003	1	コラムジョイント	COLUMN JOINT	
42-2-10	S21798001	6	スプールネジセット	SPOOL SCREW SET	
42-2-10-1	150179002	6	スプールジクB	SPOOL SHAFT, B	
42-2-10-2	028050246	6	バネザガネ2-5	WASHER, SPRING 2-5	
42-2-10-3	021500106	6	1シユナット5	NUT, 1 M5	
42-2-11	150185009	1	イトアンナイホルダー	THREAD GUIDE HOLDER	
42-2-12	138843001	1	ササエボウツギテ	JOINT	
42-2-13	150188009	1	スプールホルダーササエA	SPOOL HOLDER SUPPORT, A	
42-2-14	150194009	1	スプールホルダーササエB	SPOOL HOLDER SUPPORT, B	
42-2-15	S02779009	2	スプールホルダー3	SPOOL HOLDER, 3	
42-2-16	S02788009	2	スレッドハンガークミ3	THREAD HANGER ASSY, 3	
42-2-17	S40641001	1	スプールジクネジセットA	SPOOL SCREW SET, A	
42-2-17-1	021500106	4	1シユナット5	NUT, 1 M5	
42-2-17-2	S37038001	1	ナベコヒラザ5X14	SCREW, PAN (S/P WASHER) M5X14	
42-2-17-3	S37037001	1	ナベコヒラザ5X32	SCREW, PAN (S/P WASHER) M5X32	
42-2-17-4	062501406	2	ナベコ5X14	SCREW, PAN M5X14	
42-2-18	S40642001	1	スプールジクネジセットB	SPOOL SHAFT SCREW SET, B	
42-2-18-1	021500106	2	1シユナット5	NUT, 1 M5	
42-2-18-2	S37038001	1	ナベコヒラザ5X14	SCREW, PAN (S/P WASHER) M5X14	
42-2-18-3	S37037001	1	ナベコヒラザ5X32	SCREW, PAN (S/P WASHER) M5X32	
42-2-19	S40643001	1	ホルダーツギテネジセット	HOLDER JOINT SCREW SET	
42-2-19-1	014060632	2	アナトメ6X6クボミ	SET SCREW, SOCKET (CP) M6X6	
42-2-19-2	021500106	1	1シユナット5	NUT, 1 M5	
42-2-19-3	S37037001	1	ナベコヒラザ5X32	SCREW, PAN (S/P WASHER) M5X32	
42-2-20	S40644001	2	ホルダーツギテネジセット	HOLDER JOINT SCREW SET	
42-2-20-1	021500106	2	1シユナット5	NUT, 1 M5	
42-2-20-2	031452206	2	マルモク45X22	WOOD SCREW, ROUND M4.5X22	
42-2-20-3	062501006	2	ナベコ5X10	SCREW, PAN M5X10	





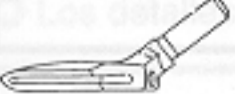





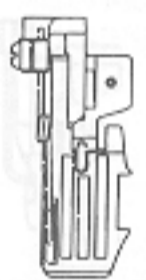



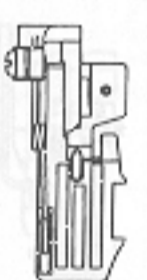











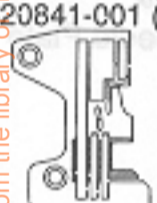
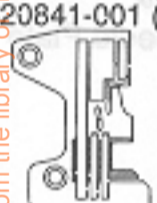





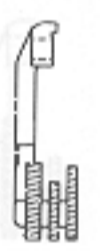

From the library of: Diamond Needle Corp

Ga1 . ゲージ部品一覧表 / Gauge parts List / Lehenliste / Liste des Pièces de cartment
/ Lista d'ePiezas de calibradores







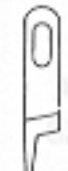
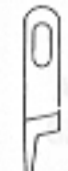
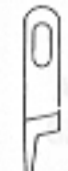
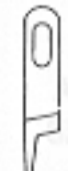
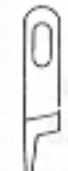
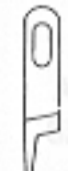
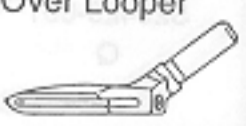
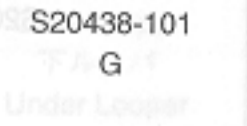
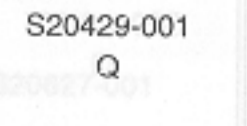
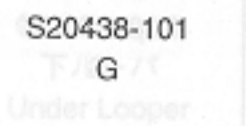
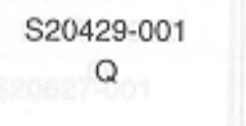
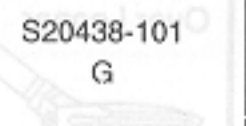

















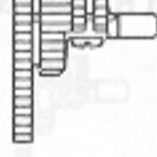
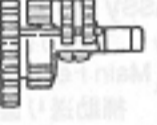

用途 Application	一般地縫用 Thin		一般地縫用 (小回り用) Thin (Small type)	一般地縫用 Thin Medium	一般地縫用 Heavy	
機種 Model	V91A	V92A	V92A	V92A	V91A	V92A
サブクラス Sub-Class H=High-Lift E=Extra High-Lift	63-3 -4 -5 -6 -7	H H H H H	63-4 (B) H -5 (B) H	64-5 H	65-3 -4 -5 -6 -7	H H H H H
針巾 (mm) Needle Gauge	3				5	
1 針 [個数] Needle [Q'ty]	151474-014 [2]				151474-016 [2]	
2 押工組 Presser Foot Assy	S19364-001 (S19367-001) (押工 F Presser Foot .F) 	S19375-101 (3) S19380-101 (4) S19383-101 (5) S20839-101 (6) S25846-101 (7) 	S25090-001 (4) S25093-001 (5) 	S19383-101 (5) 	S19370-001 (S19367-001) (押工 F Presser Foot .F) 	S25846-101 (3) S25850-101 (4) S19386-101 (5) S19389-101 (6) S25852-101 (7) 
3 針止メ組 Needle Clamp Assy	S20404-001 				S20406-001 	
4 針板 Needle Plate	S19197-001 (3) S19191-001 (4) S19192-001 (5) S20841-001 (6) S25531-001 (7) 		S20235-001 (4) S20236-001 (5) 	S19192-001 (5) 	S25532-001 (3) S25533-001 (4) S19193-001 (5) S19194-001 (6) S25534-001 (7) 	
5 主送り歯組 Main Feed Dog Assy (主送り歯 Main Feed Dog) (補助送り歯 Chain Feed Dog)	S19233-101 (S19234-101) (S19235-101) G 		S20241-101 (S20242-101) (S20243-101) H 	S19233-101 (S19234-101) (S19235-101) G 		
6 差動送り歯 Differential Feed Dog	S19250-001 	S19252-001 	S25524-001 	S19252-001 	S19251-001 	S19253-001 
7 上送り歯 Upper Feed Dog	S19403-001 	S19405-001 	S25096-001 	S19405-001 	S19403-001 	S19405-001 
8 上メス Upper Knife	144074-350 					
9 上ルーバ Over Looper 		S20428-001 C		S20421-001 L	S20428-001 C	

From the library of Diamond Needle Corp

Ga2 . ゲージ部品一覧表 / Gauge parts List / Lehrenliste / Liste des Pièces de cartment
 / Lista d'ePiezas de calibradores

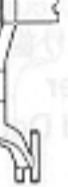

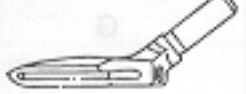







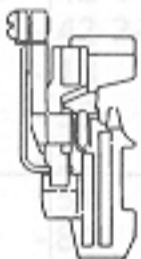

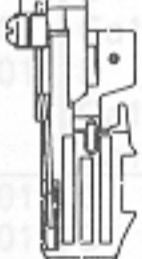
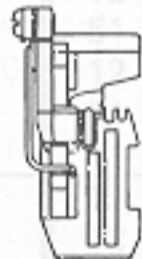
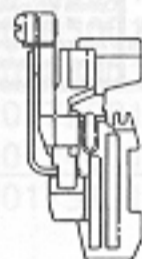



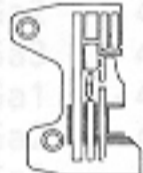

用途 Application	デニム 一般地縫用 Heavy (for vertical pocket)	一般地縫用 (3本針) Thin (3 Needles)	シャーリング用 Shirring	デニム地縫用 (3本針) Thin (3 Needles)	シャーリング用 Shirring	シャーリング用 パイピング付 Shirring W / Piping
機種 Model	V92A	V92A	V92A	V92A	V92A	V92A
サブクラス Sub-Class H=High-lift E=Extra High-Lift	66-5 H	69-4 E -5 E -6 E	70-5 E	71-5 E -6 E	72-5 E	75-4 E -5 E -6 E
針巾 (mm) Needle Gauge	5	3	3	5	5	3
1 針 [個数] Needle [Qty]	151474-016 [2]	151474-014 [2]		151474-014 (5) [2] 151474-016 (6) [2]		151474-014 [2]
2 押工組 Presser Foot Assy	S19386-101 	S19380-101 (4) S19383-101 (5) S20839-101 (6) 	S19386-101 (5) S19389-101 (6) 	S19386-101 (5) S19389-101 (6) 	S20226-001 (4, 5) S20845-001 (6) 	S20226-001 (4, 5) S20845-001 (6) 
3 針止メ組 Needle Clamp Assy	S20406-001 	S20404-001 	S20406-001 	S20406-001 	S20404-001 	S20404-001 
4 針板 Needle Plate	S19193-001 (5) 	S19191-001 (4) S19192-001 (5) S20841-001 (6) 	S19193-001 (5) S19194-001 (6) 	S19193-001 (5) S19194-001 (6) 	S19191-001 (4) S19192-001 (5) S20841-001 (6) 	S19191-001 (4) S19192-001 (5) S20841-001 (6) 
5 主送り歯組 Main Feed Dog Assy (主送り歯) (Main Feed Dog) (補助送り歯) (Chain Feed Dog)	S19233-101 (S19234-101) (S19235-101) G 	S19233-101 (S19234-101) (S19235-101) G 	S19233-101 (S19234-101) (S19235-101) G 	S19233-101 (S19234-101) (S19235-101) G 	S19233-101 (S19234-101) (S19235-101) G 	S19233-101 (S19234-101) (S19235-101) G 
6 差動送り歯 Differential Feed Dog	S19253-001 	S19252-001 	S19253-001 	S19253-001 	S19252-001 	S19252-001 
7 上送り歯 Upper Feed Dog	S19405-001 	S19405-001 	S19405-001 	S19405-001 	S19405-001 	S19405-001 
8 上メス Upper Knife	144074-350 	144074-350 	144074-350 	144074-350 	144074-350 	144074-350 
9 上ルーバ Over Looper	S20421-001 L 	S20438-101 G Under Looper 	S20429-001 Q 	S20438-101 G Under Looper 	S20429-001 Q 	S20438-101 G 

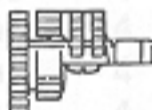
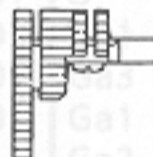
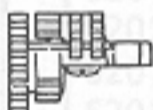
Ga3 . ゲージ部品一覧表 / Gauge parts List / Lehrenliste / Liste des Pièces decartment
/ Lista d'ePiezas de calibradores

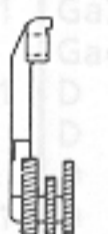
用途 Application W / Piping	シャーリング用パイピング付 Shirring W / Piping (Small type)			一般地縫用 Thin-Medium	デニム用 Heavy	一般地縫用 Medium
機種 Model	V92A	V92A	V92A	V91A	V92A	V92A
サブクラス Sub-Class H=High-Lift E=Extra High-Lift	76-5 E	77-5 E -6 E	78-5 E	92-5 E -6 E -7 E		93-6 E
針巾 (mm) Needle Gauge	3	5			5	
1 針 [個数] Needle [Q'ty]	151474-014 [2]	151474-014 (5) [2] 151474-016 (6) [2]		151474-018 [2]	151474-021 [2]	
2 押工組 Presser Foot Assy	S20226-001 	S19392-001 (5) S20847-001 (6) 		S19373-001 (S19340-001) 押工 F (Presser Foot .F) 	S19394-001 	
3 針止メ組 Needle Clamp Assy	S20404-001 	S20406-001 			S21104-001 	
4 針板 Needle Plate	S19192-001 	S19193-001 (5) S19194-001 (6) 		S19195-001 (5) S19196-001 (6) S25668-001 (7) 	S20843-001 (5) S19198-001 (6) S25669-001 (7) 	
5 主送り歯組 Main Feed Dog Assy (主送り歯 Main Feed Dog) (補助送り歯 Chain Feed Dog)		S19233-101 (S19234-101) (S19235-101) G 			S19228-101 (S19229-001) (S19223-101) F 	
6 差動送り歯 Differential Feed Dog	S19252-001 	S19253-001 		S19251-001 	S19254-001 	
7 上送り歯 Upper Feed Dog	S20228-001 			S19404-001 	S19406-001 	
8 上メス Upper Knife 角メス Angle Knife		上メス Upper knife 144074-350 			角メス Angle knife S20897-101 	
9 上ルーバ Over Lopper	S20429-001 Q 	S20438-101 G	S20429-001 Q	S20438-101 G	S20429-001 Q 	

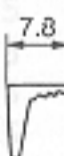

From the library of: Diamond Needle Corp

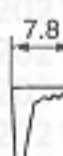
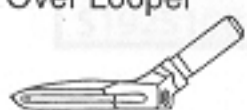
Ga4 . ゲージ部品一覧表 / Gauge parts List / Lehrenliste / Liste des Pièces de cartment
/ Lista d'ePiezas de calibradores

用途 Application	デニム Heavy 縦ポケット用 (For vertical pocket)	一般地縫用 (3本針) Thin (3needles)		デニム地縫用 (3本針) Heavy (3needles) 縦ポケット用 For vertical pocket	
	機種 Model	V92A	V92A	V92A	V92A
サブクラス Sub-Class H=High-Lift E=Extra High-Lift	92-5 (B) E -6 (B) E -7 (B) E	95-5 H	W1-5 H	W3-7 E	W3-7 (B) E
針巾 (mm) Needle Gauge	5	5, 2.2	3, 2.2	5, 3	
1 針 [個数] Needle [Q'ty]	151474-021 [2]	151474-016 [3]	151474-014 [3]	151474-018 [3]	
2 押工組 Presser Foot Assy	S30435-001 	S30118-101 	S32003-101 	S30895-001 	S49052-001 
3 針止め組 Needle Clamp Assy	S21104-001 	S29148-001 	S32005-001 	S49050-001 	
4 針板 Needle Plate	S20843-001 (5) S19198-001 (6) S25669-001 (7) 	S30120-001 	S32007-001 	S30897-001 	
5 主送り歯組 Main Feed Dog Assy (主送り歯 Main Feed Dog) (補助送り歯 Chain Feed Dog)	S19228-101 (S19229-001) (S19223-101) F 	S19233-101 (S19234-101) (S19235-101) G 	S19228-101 (S19229-001) (S19223-101) F 		
6 差動送り歯 Differential Feed Dog	S19254-001 	S19253-001 	S19254-001 		
7 上送り歯 Upper Feed Dog	S19406-001 	S19405-001 	S19406-001 		
8 上メス Upper Knife 角メス Angle Knife	角メス Angle knife S20897-101 	上メス Upper knife 144074-350 	角メス Angle knife S20897-101 		
9 上ルーバ Over Looper 	S20438-101 G	上ルーバ Over Looper 下ルーバ Under Looper	S20430-001 D S20627-001	上ルーバ Over Looper 下ルーバ Under Looper	S49054-001 S S20627-001

From the library of: Diamond Needle Corp

Wa. 警告ラベル / Warning labels / Warnschilder / Etiquettes d'avertissement / Etiquetas de advertencia

警告ラベル / Warning labels	品名 / Name of parts	Size(mm)	Code
	操作注意ラベル・和	40×64	S38350-001
	Label, operation Eng.	40×64	S38349-001
	アースマーク Mark, grounding	φ 12	S37060-001

185-V9A,B-052

From the library of: Diamond Needle Corp

索引 / INDEX / VERZEICHNIS
/ INDEX / INDICE

CODE	REF.NO.	Page
S00075000	A - 66	4
S00204001	F - 99	20
S01943001	Z - 7	46
S02573000	E - 38	14
S02606000	A - 3	2
S02775001	Z - 42-1-4	48
	Z - 42-2-4	50
S02778002	Z - 42-1-14	48
S02779009	Z - 42-1-16	48
	Z - 42-2-15	50
S02783001	Z - 42-2-6	50
S02786002	Z - 42-1-15	48
S02788009	Z - 42-1-17	48
	Z - 42-2-16	50
S02874001	P - 1-3	38
S04109001	Z - 42-1-5	48
	Z - 42-2-5	50
S06701000	Z - 18	46
S06704001	Z - 39	46
	Z - 39	46
S07463000	L - 51	32
S07477009	A - 84	4
S08956100	L - 8	30
	Z - 68	46
	Z - 68	46
S08957001	L - 7	30
S12987002	L - 10	30
S19191001	Ga1 - 4	51
	Ga2 - 4	52
S19192001	Ga1 - 4	51
	Ga2 - 4	52
	Ga3 - 4	53
S19193001	Ga1 - 4	51
	Ga2 - 4	52
	Ga3 - 4	53
S19194001	Ga1 - 4	51
	Ga2 - 4	52
	Ga3 - 4	53
S19195001	Ga3 - 4	53
S19196001	Ga3 - 4	53
S19197001	Ga1 - 4	51
S19198001	Ga3 - 4	53
	Ga4 - 4	54
S19223101	Ga3 - 5	53
	Ga4 - 5	54
S19228101	Ga3 - 5	53
	Ga4 - 5	54
S19229001	Ga3 - 5	53
	Ga4 - 5	54
S19233101	Ga1 - 5	51
	Ga2 - 5	52
	Ga3 - 5	53
	Ga4 - 5	54
S19234101	Ga1 - 5	51
	Ga2 - 5	52
	Ga3 - 5	53
	Ga4 - 5	54
S19235101	Ga1 - 5	51
	Ga2 - 5	52
	Ga3 - 5	53
	Ga4 - 5	54
S19250001	Ga1 - 6	51
S19251001	Ga1 - 6	51

CODE	REF.NO.	Page
S19251001	Ga3 - 6	53
S19252001	Ga1 - 6	51
	Ga2 - 6	52
	Ga3 - 6	53
S19253001	Ga1 - 6	51
	Ga2 - 6	52
	Ga3 - 6	53
	Ga4 - 6	54
S19254001	Ga3 - 6	53
	Ga4 - 6	54
S19311101	D - 50-3-1	12
	D - 50-4-1	12
S19340001	D - 50-3-2	12
	Ga3 - 2	53
S19346001	D - 50-1-5	12
	D - 50-3-1	12
S19364001	Ga1 - 2	51
S19367001	D - 50-1-2	12
	Ga1 - 2	51
	Ga1 - 2	51
S19368001	D - 50-1-1	12
S19369001	D - 50-1-4	12
S19370001	Ga1 - 2	51
S19373001	Ga3 - 2	53
S19375101	Ga1 - 2	51
S19379001	D - 50-1-1	12
	D - 50-12-1	12
S19380101	Ga1 - 2	51
	Ga2 - 2	52
S19383101	Ga1 - 2	51
	Ga2 - 2	52
S19386101	Ga1 - 2	51
	Ga2 - 2	52
S19389101	Ga1 - 2	51
	Ga2 - 2	52
S19392001	Ga3 - 2	53
S19394001	Ga3 - 2	53
S19399001	D - 50-4-2	12
S19403001	Ga1 - 7	51
S19404001	Ga3 - 7	53
S19405001	Ga1 - 7	51
	Ga2 - 7	52
	Ga4 - 7	54
S19406001	Ga3 - 7	53
	Ga4 - 7	54
S19535001	D - 51	12
	D - 51	12
	D - 51	12
S20115001	D - 38-2	12
S20118151	Z - 91	46
S20130009	R - 5-6	44
S20131009	R - 5-6-1	44
S20134001	R - 5-6-1-1	44
S20135001	R - 5-6-1-2	44
S20139101	F - 1	18
S20144000	F - 3	18
S20145001	F - 4	18
S20146001	F - 8	18
S20147001	F - 13	18
S20151001	F - 15	18
S20152001	F - 14	18
S20153001	F - 17	18
	F - 54	20

CODE	REF.NO.	Page
S20154001	F - 21	18
S20155000	F - 59	20
S20156000	F - 23	18
	F - 60	20
S20157001	F - 26	18
S20158101	F - 13-2	18
	F - 52-2	20
	L - 53	32
	L - 56	32
	M - 72	36
S20159001	F - 30	18
S20160001	F - 32	18
	F - 71	20
S20161101	F - 34	18
S20162001	F - 36	18
S20163001	F - 42	18
S20165001	F - 45	18
S20168001	F - 52	20
S20172001	F - 53	20
S20174001	F - 58	20
S20175101	F - 5	18
	F - 13-1	18
	F - 18	18
	F - 52-1	20
	F - 55	20
S20176001	F - 64	20
S20177001	F - 69	20
S20178001	L - 57	32
S20179001	F - 72	20
S20180001	L - 29	30
S20181001	F - 82	20
S20182001	F - 82-1	20
S20183001	F - 84	20
S20184101	F - 50	18
S20189001	F - 33	18
	F - 83	20
	F - 104	20
S20191001	F - 82-3	20
S20193001	F - 92	20
S20194001	F - 95	20
S20195001	F - 97	20
S20197001	F - 24	18
	F - 28	18
	F - 62	20
	F - 67	20
S20199001	L - 14	30
	L - 16	30
	L - 18	30
S20200001	L - 30	30
S20201001	F - 101	20
S20202001	F - 100	20
S20204001	A - 2	2
S20207101	A - 57	4
S20208001	A - 56	4
S20209001	D - 20	10
S20213000	L - 40	32
S20214000	L - 42	32
S20215001	L - 43	32
S20216000	L - 45	32
S20217001	L - 46	32
S20218001	L - 49	32
S20219001	L - 50	32
S20220001	L - 52	32

CODE	REF.NO.	Page
S20221000	L - 54	32
S20222001	L - 55	32
S20226001	Ga2 - 2	52
	Ga3 - 2	53
S20228001	Ga2 - 7	52
	Ga3 - 7	53
S20235001	Ga1 - 4	51
S20236001	Ga1 - 4	51
S20241101	Ga1 - 5	51
S20242101	Ga1 - 5	51
S20243101	Ga1 - 5	51
S20298001	D - 36	10
S20300101	L - 4	30
S20301001	L - 4-3	30
S20303000	L - 4-4	30
S20306000	A - 5	2
S20309101	A - 11	2
S20310001	A - 13	2
S20311000	A - 14	2
S20313000	A - 20	2
S20314000	A - 21	2
S20319001	A - 27-3	2
S20320101	A - 27-5	2
S20321001	A - 27-6	2
S20324101	A - 33	2
S20325001	A - 35	2
S20327101	A - 27-8	2
S20328001	A - 37	2
S20330100	A - 39	2
S20331001	A - 40	2
S20334000	A - 43	2
S20337001	A - 59	4
S20338200	A - 61	4
S20339000	A - 62	4
S20340001	A - 69	4
S20342001	A - 70	4
	M - 65	36
S20344009	A - 74	4
S20345009	A - 10	2
	A - 75	4
S20346000	A - 80	4
S20353000	B - 21	6
S20355002	H - 9-2-2	24
	R - 5-13	44
S20356001	B - 11	6
S20361001	B - 17	6
S20362151	B - 18	6
S20386101	C - 7	8
S20391001	C - 7-4	8
S20392000	C - 7-5	8
	L - 34	30
S20393101	C - 8	8
S20404001	Ga1 - 3	51
	Ga2 - 3	52
	Ga3 - 3	53
S20406001	Ga1 - 3	51
	Ga2 - 3	52
	Ga3 - 3	53
S20412000	A - 48	2
	A - 55	4
	Z - 67	46
S20413051	C - 18	8
S20414001	C - 20	8

CODE	REF.NO.	Page
S20415101	C - 22	8
S20416101	C - 23	8
S20418051	C - 24	8
S20421001	Ga1 - 9	51
	Ga2 - 9	52
S20428001	Ga1 - 9	51
S20429001	Ga2 - 9	52
	Ga3 - 9	53
S20430001	Ga4 - 9	54
S20438101	Ga2 - 9	52
	Ga3 - 9	53
	Ga4 - 9	54
S20453001	P - 1	38
S20454000	P - 1-1	38
S20455000	P - 1-2	38
S20456000	P - 1-5	38
S20459000	P - 1-6	38
S20460000	P - 1-7	38
	P - 5-2	38
S20461101	P - 5	38
S20464000	P - 5-1	38
S20467001	P - 5-5	38
S20472001	D - 1	10
S20477001	D - 4	10
S20485001	D - 19	10
S20489001	D - 23	10
S20496101	E - 1	14
S20500001	E - 1-2	14
	F - 1-1	18
S20500002	E - 1-2	14
	F - 1-1	18
S20500003	E - 1-2	14
	F - 1-1	18
S20507001	E - 3-1	14
S20523000	E - 43	14
S20524000	E - 44	14
S20525001	E - 45	14
S20526000	E - 47	14
S20527001	E - 83	16
S20530001	E - 30	14
S20543101	E - 51	14
S20544000	E - 52	14
S20546001	F - 27	18
	F - 65	20
S20547001	E - 55	16
S20548001	E - 59	16
S20554001	E - 58	16
S20560001	E - 66	16
	F - 41	18
	F - 78	20
S20561001	E - 67	16
S20571101	G - 2	22
S20574001	G - 8	22
S20577001	G - 12	22
S20578101	G - 13	22
S20579101	G - 15-2	22
S20582001	G - 22	22
	Z - 4	46
S20585001	G - 27	22
S20589101	G - 9-1	22
S20590101	G - 9-2	22
S20591101	G - 17	22
S20598000	H - 2	24

CODE	REF.NO.	Page
S20598000	J - 3	26
S20601001	H - 5	24
S20621001	F - 105	20
S20625151	J - 11	26
S20626001	J - 14-1	26
S20627001	J - 14-2	26
	Ga4 - 9	54
	Ga4 - 9	54
S20640001	K - 10	28
S20641001	K - 11	28
S20649051	K - 20	28
S20652001	K - 24	28
S20653001	K - 27	28
S20654001	K - 29	28
S20655101	L - 1	30
S20657001	L - 4-1	30
S20661001	L - 4-5	30
S20662100	L - 4-6	30
S20663000	L - 4-7	30
S20666001	L - 17	30
S20668200	L - 22	30
S20669000	L - 24	30
S20672001	M - 1	34
S20673001	M - 11	34
S20675001	M - 8	34
S20676051	M - 9	34
	R - 2-1-5	40
S20677000	M - 10	34
S20678001	M - 14-1	34
	M - 14-1	36
S20679001	M - 15	34
S20681000	M - 17	34
	R - 2-1-7	40
S20682101	M - 18-2	34
S20682102	M - 18-4	34
S20682103	M - 18-1	34
S20682104	M - 18-3	34
S20682105	M - 18-5	36
	R - 2-1-8	40
S20683001	M - 19	34
S20684101	M - 23	34
S20685001	M - 25	34
S20686001	M - 26	34
S20687001	M - 37	34
S20689001	M - 48	34
S20690001	M - 49	34
S20691001	M - 50	34
S20693001	M - 5-1	34
S20694001	M - 53	34
S20695001	M - 55	34
S20696001	M - 56	34
S20697001	M - 58	34
S20698121	M - 59	34
S20701001	M - 66	36
S20702001	M - 71	36
S20703051	M - 73	36
S20707001	M - 75	36
S20718000	Z - 27	46
S20719000	Z - 34	46
S20721001	Z - 64-1	48
S20722001	Z - 64-10	48
S20723001	Z - 12	46
S20740101	E - 46	14

From the library of: Diamond Needle Corp

CODE	REF.NO.	Page
S20743001	M - 51	34
S20769000	Z - 40	46
S20788001	D - 40	12
S20839101	Ga1 - 2	51
	Ga2 - 2	52
S20841001	Ga1 - 4	51
	Ga2 - 4	52
S20843001	Ga3 - 4	53
	Ga4 - 4	54
S20845001	Ga2 - 2	52
S20847001	Ga3 - 2	53
S20878000	A - 19	2
	A - 82	4
S20896101	G - 15-2	22
S20897101	G - 15-2	22
	Ga3 - 8	53
	Ga4 - 8	54
S20898101	G - 15-2	22
S21017001	D - 50-1-2	12
	D - 50-3-2	12
	D - 50-12-2	12
S21091000	E - 81	16
S21092000	E - 81-1	16
S21104001	Ga3 - 3	53
	Ga4 - 3	54
S21125001	M - 44-1	34
S21126001	M - 40-1	34
S21127001	M - 38-1	34
S21128001	M - 44-2	36
S21129001	M - 40-2	36
S21130051	M - 42	34
S21133001	M - 28	34
S21134001	M - 29	34
S21135001	M - 31	34
S21136101	M - 35	34
S21137001	M - 33	34
S21283001	R - 3-1-3	42
	R - 3-1-3	42
S21294001	R - 2-1-1	40
S21295001	R - 2-1-2	40
S21297001	R - 2-1-12	40
S21298001	R - 2-1-15	40
S21299001	R - 2-1-17	40
S21300001	R - 2-1-19	40
S21301001	R - 2-1-23	40
S21302001	R - 2-1-24	40
S21303001	R - 2-1-26	40
S21304001	R - 2-1-28	40
S21305001	R - 2-1-3	40
S21306001	R - 2-1-13	40
S21307001	R - 2-1-14	40
S21310001	R - 6-1	40
S21311001	R - 6-2	40
S21312001	R - 6-3	40
S21313001	R - 6-6	40
S21314001	R - 6-7	40
S21315001	R - 6-9	40
S21316001	R - 6-11	40
S21336101	Q - 1	38
S21341001	Q - 1-6	38
S21365001	R - 2-1	40
S21366001	R - 2-1-9	40
S21368001	R - 5-10	44

CODE	REF.NO.	Page
S21369001	R - 5-12	44
S21370001	R - 5-3	44
S21372001	R - 5-3	44
S21374101	R - 3-2-1	42
S21376001	R - 3-1-1-9	42
	R - 3-2-1-9	42
S21377001	R - 3-1-1-11	42
	R - 3-2-1-11	42
S21378001	R - 3-1-1-12	42
	R - 3-2-1-12	42
S21382001	R - 3-1-1-16	42
	R - 3-1-1-16	42
S21384001	R - 3-1-4	42
	R - 3-1-4	42
S21385001	R - 3-1-2	42
	R - 3-1-2	42
S21387101	R - 3-1-1	42
S21388001	R - 3-1-1-2	42
	R - 3-2-1-2	42
S21590000	R - 2-4	40
S21798001	Z - 42-1-10	48
	Z - 42-2-10	50
S23337009	A - 7	2
	A - 83	4
S23341009	D - 31	10
	F - 98	20
S23342001	C - 1-2	8
	C - 7-1	8
	G - 1-3	22
	H - 9-1-1	24
S23346101	H - 1-2	24
S23349001	D - 45	10
S23350001	A - 63	4
S23351001	A - 65	4
S23353001	Z - 58	46
S23356001	Z - 10	46
S23357001	A - 79	4
S23360001	E - 37	14
	E - 42	14
	K - 18	28
S23364000	D - 44	10
S23367001	A - 16	2
S23418002	A - 60	4
	C - 21	8
	M - 27	34
	P - 2	38
	R - 2-5	40
S23452002	M - 22	34
	M - 74	36
S23453001	E - 84	16
S23456101	C - 25	8
	K - 30	28
S23458101	E - 7	14
S23460001	L - 4-11	30
S23611101	H - 15	24
S23612051	E - 73	16
S23614101	J - 12	26
	K - 25	28
S23615001	E - 5	14
S23616101	A - 25-2	2
	E - 82	16
S23619001	F - 12	18
	G - 6	22

CODE	REF.NO.	Page
S23619001	H - 6	24
S23621101	E - 72	16
	E - 76	16
	E - 78	16
	F - 103	20
	G - 16-1	22
S23626001	H - 7	24
	J - 6	26
S23628051	E - 71	16
S23651002	R - 2-1-18	40
	R - 5-11	44
S23773001	Q - 1-2	38
S23774001	R - 6-8	40
S23775001	R - 2-1-6	40
S23777101	R - 2-1-4	40
S23779001	R - 2-6	40
S23896101	Q - 1-1	38
S23897001	Q - 1-4	38
S24473000	Z - 14	46
S25090001	Ga1 - 2	51
S25093001	Ga1 - 2	51
S25096001	Ga1 - 7	51
S25182001	A - 92	4
S25183001	A - 92	4
S25184001	A - 93	4
S25524001	Ga1 - 6	51
S25525101	F - 103	20
S25526000	L - 35	30
S25530001	B - 1-1	6
S25531001	Ga1 - 4	51
S25532001	Ga1 - 4	51
S25533001	Ga1 - 4	51
S25534001	Ga1 - 4	51
S25668001	Ga3 - 4	53
S25669001	Ga3 - 4	53
	Ga4 - 4	54
S25818051	E - 61	16
	F - 46	18
	F - 79	20
S25846101	Ga1 - 2	51
S25848101	Ga1 - 2	51
S25850101	Ga1 - 2	51
S25852101	Ga1 - 2	51
S25879001	L - 32	30
S27868001	B - 16	6
S28044009	F - 11	18
S29094001	E - 69	16
S29102001	K - 6	28
S29132001	F - 43	18
S29148001	Ga4 - 3	54
S29700000	H - 9-3	24
S29855109	Z - 42-1	48
S29864109	Z - 42-2	50
S29933000	P - 5-3	38
S29934000	P - 5-4	38
S30118101	Ga4 - 2	54
S30120001	Ga4 - 4	54
S30121001	M - 5-2	36
S30122001	M - 38-2	36
S30137001	R - 6	40
S30140001	D - 38-1	12
S30401001	R - 2	40
S30402101	R - 3-1	42

From the library of: Diamond Needle Supply

CODE	REF.NO.	Page
S30402102	R - 3-2	42
S30404001	R - 5	44
S30411003	R - 7	44
S30411004	R - 7	44
S30411005	R - 7	44
S30411006	R - 7	44
S30412004	R - 7	44
S30412005	R - 7	44
S30412006	R - 7	44
S30413103	R - A	44
S30413104	R - A	44
S30413105	R - A	44
S30413106	R - A	44
S30414104	R - A	44
S30414105	R - A	44
S30414106	R - A	44
S30435001	Ga4 - 2	54
S30517101	A - 73	4
S30562000	E - 18	14
S30890000	G - 15-6	22
S30895001	Ga4 - 2	54
S30897001	Ga4 - 4	54
S31115103	R - A	44
S31115104	R - A	44
S31115105	R - A	44
S31115106	R - A	44
S31116104	R - A	44
S31116105	R - A	44
S31116106	R - A	44
S31867001	A - 92	4
S31881101	K - 12	28
S32003101	Ga4 - 2	54
S32005001	Ga4 - 3	54
S32007001	Ga4 - 4	54
S32276001	M - 14-2	34
S34326000	B - 23	6
S35997001	Z - 29	46
	Z - 64-3	48
S36007001	Z - 64-4	48
S37037001	Z- 42-1-18-3	48
	Z- 42-1-19-3	48
	Z- 42-1-20-3	48
	Z- 42-2-17-3	50
	Z- 42-2-18-3	50
	Z- 42-2-19-3	50
S37038001	Z- 42-1-18-2	48
	Z- 42-1-19-2	48
	Z- 42-2-17-2	50
	Z- 42-2-18-2	50
S37060001	Wa	55
S37070121	D - 34	10
S38305001	A - 29	2
S38306051	C - 26	8
S38307001	C - 28	8
S38312050	E - 24	14
S38320100	H - 9-2-1	24
S38330050	M - 46	34
S38349001	Wa	55
S38350001	Wa	55
S38645001	Z - 65	46
S38648001	Z - 42-1-4-2	48
	Z - 42-2-4-2	50
S39564021	A - 23	2

CODE	REF.NO.	Page
S39565101	B - 24	6
S39571021	C - 10	8
S39577000	D - 2-1	10
S39589021	E - 8	14
S39593021	E - 54	16
S39596021	E - 54-1	16
S39607001	A - 8	2
S39611001	A - 27	2
S39612001	A - 27-1	2
S39613001	A - 27-2	2
S39625151	A - 49	2
S39629021	B - 3	6
S39630000	B - 10	6
S39631000	B - 20	6
S39644021	C - 2	8
S39645021	C - 3	8
S39646021	C - 4	8
S39647000	C - 5	8
S39648021	C - 9	8
S39649021	C - 14	8
S39650051	C - 16	8
S39654051	C - 30	8
S39660001	D - 7	10
S39661001	D - 8	10
S39662001	D - 9	10
S39663021	D - 11	10
S39664001	D - 12	10
S39665001	D - 15	10
S39671101	D - 26	10
S39672001	D - 29	10
S39674001	E - 9	14
S39675001	E - 10	14
S39676121	E - 15	14
S39677021	E - 16	14
	F - 10	18
	G - 5	22
	H - 4	24
	J - 9	26
S39678021	E - 17	14
S39679001	E - 20	14
S39683000	E - 26	14
S39684021	E - 27	14
S39685001	E - 28	14
S39690021	E - 36	14
	E - 41	14
	K - 8	28
	K - 19	28
S39691001	E - 39	14
S39692021	E - 50	14
S39694021	E - 64	16
	F - 39	18
	F - 76	20
S39695001	E - 65	16
	F - 40	18
	F - 77	20
S39704021	G - 4	22
S39707001	G - 19	22
S39708001	G - 25	22
S39709021	G - 28	22
S39728021	F - 9	18
	H - 3	24
	J - 8	26
S39729021	K - 1	28

CODE	REF.NO.	Page
S39732021	K - 3	28
S39733001	D - 27	10
	K - 4	28
S39734021	K - 7	28
S39741021	K - 21	28
S39742021	K - 22	28
S39756021	M - 63	36
S39757001	M - 67	36
S39769051	E - 40	14
S39773001	E - 35	14
S40640001	Z - 42-1-7	48
	Z - 42-2-7	50
S40641001	Z - 42-1-18	48
	Z - 42-2-17	50
S40642001	Z - 42-1-19	48
	Z - 42-2-18	50
S40643001	Z - 42-1-20	48
	Z - 42-2-19	50
S40644001	Z - 42-1-21	48
	Z - 42-2-20	50
S42042021	E - 33	14
S43453001	A - 97	4
S43521000	L - 36-2	30
S43522000	L - 36-1	30
S43523000	L - 36	30
S43916001	E - 48	14
S44535001	A - 25-3	2
S44536000	A - 24	2
S44821001	A - 94	4
S44935001	K - 14	28
S44937001	K - 15	28
S44939001	K - 16	28
S46839000	D - 24	10
S46840001	D - 6	10
S46841001	D - 53	10
S46842001	D - 54	10
S46843001	D - 56	10
S46844001	F - 87	20
S46849001	D - 21	10
S46887001	D - 2	10
S46889001	D - 5	10
S46891001	E - 23	14
S46895001	E - 68	16
S46896001	H - 9	24
S46899001	C - 7-2	8
	D - 22	10
	H - 9-1-2	24
S46900001	B - 13	6
S46901001	H - 9	24
S46903001	D - 30	10
	H - 13	24
S46904001	J - 5	26
S46905001	L - 12	30
S46907001	Z - 11	46
S46908001	D - 5	10
S46923001	B - 1	6
S46931001	C - 1	8
S46932001	C - 1	8
S46936001	G - 1	22
S46940001	H - 1	24
S46943001	J - 1	26
S46944001	J - 1	26
S47031000	F - 22	18

From the library of: Diamond Needle Corp

CODE	REF.NO.	Page
S49050001	Ga4 -3	54
S49052001	Ga4 -2	54
S49054001	Ga4 -9	54
S49337000	L -28	30
004350812	E -31	14
011502012	D -47	10
012060632	B -25	6
	D -25	10
	E -2	14
	E -4	14
	E -73-1	16
	F -1-3	18
	F -7	18
	F -12-1	18
	F -20	18
	F -57	20
	F -93	20
	G -6-1	22
	H -6-1	24
	J -2	26
	R -6-4	40
012400432	A -27-4	2
	A -32	2
	A -40-1	2
	D -28	10
	E -29	14
	F -25	18
	F -29	18
	F -63	20
	F -68	20
	F -82-2	20
	H -13	24
	K -5	28
	R -6-12	40
012400536	L -4-2	30
012400632	A -42	2
	F -96	20
012400832	A -31	2
	E -32	14
012500532	L -2	30
014060632	Z-42-1-20-1	48
	Z-42-2-19-1	50
014780622	R -3-1-1-6	42
	R -3-1-1-19	42
	R -3-1-1-19	42
	R -3-2-1-6	42
017060812	H -8	24
	J -7	26
017061612	C -1-3-1	8
	G -1-2-1	22
017081606	R -3-1-1-8	42
	R -3-2-1-8	42
017085502	Z -64-5	48
017500812	G -26	22
017501212	A -64	4
017781012	R -3-1-1-4	42
	R -3-1-1-10	42
	R -3-1-1-13	42
	R -3-1-1-15	42
	R -3-1-1-15	42
	R -3-2-1-4	42
	R -3-2-1-10	42
	R -3-2-1-13	42

CODE	REF.NO.	Page
018061432	E -53	14
	H -10	24
	K -12-1	28
	K -14-1	28
	L -6	30
018061632	E -8-1	14
	E -34	14
	E -40-1	14
	E -60	16
	F -31	18
	F -70	20
	F -86	20
018062532	B -28	6
	C -15	8
	D -13	10
018401032	R -2-3	40
018401622	C -1-1-1	8
	F -1-2	18
	G -1-1	22
	H -1-1	24
	J -1-1	26
018401632	R -2-2	40
021060302	R -2-1-20	40
	R -2-7	40
021080106	Z -33	46
	Z -64-8	48
021350106	F -51	18
021400106	Z -70	46
	Z -70	46
021400202	F -91	20
021400212	A -53	4
	Q -1-5	38
	R -2-1-22	40
	R -6-10	40
021500106	Z-42-1-10-3	48
	Z-42-1-18-1	48
	Z-42-1-19-1	48
	Z-42-1-20-2	48
	Z-42-1-21-1	48
	Z-42-2-10-3	50
	Z-42-2-17-1	50
	Z-42-2-18-1	50
	Z-42-2-19-2	50
	Z-42-2-20-1	50
021500216	K -9	28
021500303	R -6-7-1	40
021500312	D -48	10
025030132	G -14	22
025040132	A -45	2
	E -49	14
	G -11	22
	P -4	38
025040332	Z -60	46
025050132	A -72	4
025060236	F -37	18
	F -85	20
025060332	D -14	10
025080236	Z -64-6	48
025350332	A -68	4
	E -63	16
	R -5-5	44
025710132	F -106	18
025710232	E -12	14

CODE	REF.NO.	Page
025710232	E -13	14
025770232	R -3-1-1-18	42
	R -3-1-1-18	42
028050242	M -64	36
028050246	Z-42-1-10-2	48
	Z-42-2-10-2	50
028060242	B -27	6
028080242	Z -32	46
	Z -64-7	48
031411304	Z -57	46
031452206	Z-42-1-21-2	48
	Z-42-2-20-2	50
032422505	R -3-1-5	42
	R -3-1-5	42
034422006	R -5-6-2	44
047250842	E -1-1	14
047301642	D -2-2	10
047401642	D -21-1	10
047502542	E -57	16
047602042	A -54	4
048040342	E -14	14
	E -70	16
	F -44	18
048090342	E -19	14
048400242	B -14	6
060300412	D -35	10
	M -30	34
060300512	Z -92	46
060300612	D -39	12
	D -39	12
	M -52	34
060350812	A -67	4
	E -62	16
	J -16	26
	K -28	28
060351012	J -15	26
060400512	A -96	4
	L -17-1	30
060400612	A -12	2
	A -27-7	2
	A -27-9	2
	A -34	2
	A -36	2
	A -46	2
	A -50	2
	D -10	10
	E -22	14
	H -16	24
	M -24	34
	M -32	34
	M -36	34
	M -39	34
	M -41	34
	M -45	34
	M -54	34
	M -57	34
	M -76	36
060400812	A -15	2
	A -17	2
	D -46	10
	F -75	20
	G -29	22
	L -11	30

CODE	REF.NO.	Page
060400812	L -26	30
	L -33	30
	M -4	34
	M -20	34
	M -43	34
	Z -64-11	48
	Z -64-12	48
060401012	A -25-1	2
	A -47	2
	P -3	38
060401412	A -28	2
	F -89	20
	M -68	36
060630712	E -75-1	16
061400812	A -18	2
	A -26	2
	A -58	4
	B -6	6
	L -23	30
062060812	G -18	22
	G -21	22
062061012	F -38	18
062061412	Z -66	46
062300412	G -16-2	22
062300512	F -16	18
	Q -1-7	38
062300612	K -17	28
062300812	C -29	8
	R -2-1-11	40
062350512	R -2-1-27	40
062350612	D -37	10
	F -35	18
	F -48	18
	F -81	20
	M -70	36
	Q -1-9	38
	R -5-4	44
062350812	C -7-3	8
	C -27	8
	R -6-5	40
062351016	L -4-8	30
062400612	A -30	2
	C -19	8
	L -44	32
	L -47	32
	L -58	32
	R -2-1-25	40
	Z -59	46
062400812	A -9	2
	B -5	6
	R -2-1-16	40
062401012	A -22	2
	B -22	6
	C -17	8
	C -31	8
	E -6	14
	P -6	38
	Q -2	38
	R -3-1-6	42
	R -3-2-6	42
062401212	A -4	2
	A -52	4
	G -10-1	22

CODE	REF.NO.	Page
062401406	Z -71	46
	Z -71	46
062401612	A -81	4
	D -57	10
	R -2-1-21	40
062402512	G -10-2	22
062501006	Z-42-1-21-3	48
	Z-42-2-20-3	50
062501212	F -88	20
062501406	Z-42-1-18-4	48
	Z-42-2-17-4	50
062670712	D -41	12
	D -50-1-4	12
	D -50-3-4	12
	D -50-3-4	12
	D -50-4-4	12
	D -50-12-4	12
072600000	B -7	6
076203000	B -15	6
081005070	E -11	14
	F -94	20
081005670	E -56	16
	F -66	20
081008070	L -5	30
081009070	A -77	4
081020070	E -21	14
081031870	B -4	6
081044070	L -9	30
100032003	C -33	8
100136001	R -5-1-4	44
101118001	R -5-2	44
101572101	Z -5	46
102707002	F -74	20
	R -2-8	40
104450101	C -11	8
105161004	D -3	10
	F -47	18
	F -80	20
106640001	D -50-1-3	12
	D -50-3-3	12
108494001	R -5-1-2	44
108495001	R -5-1-3	44
110744002	R -3-1-1-17	42
	R -3-1-1-17	42
110832009	M -12	34
116016001	Z -72	46
	Z -72	46
117466000	Z -13	46
118735002	C -1-3-2	8
	G -1-2-2	22
118770001	A -44	2
122991001	Z -25	46
125324001	G -11-2	22
126863001	Z -42-1-3	48
	Z -42-2-3	50
138843001	Z -42-1-12	48
	Z -42-2-12	50
140530002	D -52	12
	D -52	12
	D -52	12
142002001	Z -8	46
142262001	Z -24	46
142628001	E -25	14

CODE	REF.NO.	Page
142999101	Z -42-1-6	48
143767002	R -5-1	44
143980001	R -5-1-1	44
144074350	G -15-1	22
	Ga1 -8	51
	Ga2 -8	52
	Ga3 -8	53
	Ga4 -8	54
144103009	M -13	34
144225002	Z -41	46
144504001	M -60	34
144784001	R -2-1-10	40
144875001	L -4-9	30
144876001	L -4-10	30
145277205	Z -19	46
146293001	C -6	8
146427001	C -12-1	8
	M -47	34
146532001	F -6	18
	F -19	18
	F -56	20
146592001	M -21	34
146598001	A -71	4
	Q -1-3	38
146762001	Q -1-8	38
147363000	L -48	32
147893009	Z -69	46
	Z -69	46
147919051	Z -48-1	46
147919052	Z -48-2	46
147942001	L -12-1	30
148084001	L -20	30
148294001	D -50-1-3	12
	D -50-3-3	12
	D -50-12-3	12
148782001	J -13	26
	K -26	28
148797001	R -3-1-1-5	42
	R -3-2-1-5	42
148798109	R -3-1-1-7	42
	R -3-2-1-7	42
149570001	Z -9	46
150173003	Z -42-1-9	48
	Z -42-2-9	50
150174000	Z -42-1-7-1	48
	Z -42-2-7-1	50
150179002	Z-42-1-10-1	48
	Z-42-2-10-1	50
150180001	Z -42-1-1	48
	Z -42-2-1	50
150182000	Z -42-1-2	48
	Z -42-2-2	50
150185009	Z -42-1-11	48
	Z -42-2-11	50
150188009	Z -42-1-13	48
	Z -42-2-13	50
150194009	Z -42-2-14	50
150206002	Z -42-1-4-1	48
	Z -42-2-4-1	50
150307000	P -1-4	38
150755001	D -50-4-3	12
150813001	M -69	36
151474014	Ga1 -1	51

CODE	REF.NO.	Page
151474014	Ga2 -1	52
	Ga3 -1	53
	Ga4 -1	54
151474016	Ga1 -1	51
	Ga2 -1	52
	Ga3 -1	53
	Ga4 -1	54
151474018	Ga3 -1	53
	Ga4 -1	54
151474021	Ga3 -1	53
	Ga4 -1	54
151951001	F -49	18
153318201	Z -64-2	48
155162001	C -7-6	8
	H -9-1-3	24
	K -12-2	28
	K -14-2	28
	R -3-1-1-1	42
155197101	R -3-2-1-1	42
	R -3-1-1-3	42
155199101	R -3-1-1-14	42
	R -3-1-1-14	42
	R -3-2-1-3	42
	G -3	22
	H -11	24
155247000	J -10	26
	K -23	28
155261000	M -62	36
155510001	F -61	20
155539000	B -12	6
155559001	Z -42-1-8	48
	Z -42-2-8	50
156112003	A -51	2
156482000	D -55	10
	J -17	26
158722002	M -61	34
158782101	Z -56	46
183797009	Z -64	48
183798001	Z -31	46
213650001	Z -64-9	48

From the library of: Diamond Needle Corp